

# CRACK PRO

## Owner's Manual For 60 & 100 Gallon Models



SealMaster®

**SealMaster®**



Pavement Products & Equipment

PO Box 2277 • Sandusky, Ohio 44870 • 419-626-4375

# ThorWorks Industries, Inc.

Item Purchased: \_\_\_\_\_ Model No.: \_\_\_\_\_  
Serial No.: \_\_\_\_\_ Acceptance/Ship Date: \_\_\_\_\_  
Company: \_\_\_\_\_ Contact: \_\_\_\_\_  
Address: \_\_\_\_\_ City: \_\_\_\_\_  
Zip/Postal Code: \_\_\_\_\_ State: \_\_\_\_\_ Country: \_\_\_\_\_

## CORRESPONDENCE

All correspondence regarding this equipment or general correspondence should be addressed to:

**ThorWorks Industries, Inc.**  
**PO Box 2277**  
**Sandusky, OH 44870**

In referring to the equipment, kindly state the Model Number, Serial Number and any Part Number involved.



# Table Of Contents

Warranty	1
Operating Instructions	2-3
Parts List	4-5
LP Gas Schematic	6
Assembly Schematics	7-9
Hydraulic Oil Specifications	10-11
Hydraulic Oil MSDS	12-18
Heat Transfer Oil Specifications	19
Heat Transfer Oil MSDS	20-26

## SealMaster Limited Warranty

SealMaster warrants that its products are of quality material and workmanship. SealMaster agrees to replace, within a period of one (1) year from date of delivery, or at its option, repair, without charge, any part of their manufacture which proved defective. The repair or replacement will be free of charge F.O.B Sandusky, Ohio, proving the damaged part or parts are returned, freight prepaid, to SealMaster and investigation show such repair or replacement is made necessary by inherent defect of material or workmanship.

It is hereby understood that engines, motors, pumps, or other components purchased by SealMaster for use on its equipment are not warranted by SealMaster and are sold only with the standard warranty of the manufacturer of that component.

SealMaster will make no allowances for repairs or alterations completed by outside sources unless authorization is in writing and approved by an authorized SealMaster representative.

Any claims for defective material or workmanship must be made prior to the expiration of thirty (30) days from the date failure occurs, and in all cases prior to the expiration of the warranty period of one (1) year. It is the intent of this paragraph to limit SealMaster's liability solely to the cost of replacement parts, F.O.B. factory, or at the option of SealMaster to repair of the defective part or parts. No allowances for damages, lost time, or any other claim will be recognized.

This warranty is null and void if other than genuine SealMaster parts are used.

SealMaster is constantly striving to improve their products. Changes in design and improvement will be made whenever the manufacturer believes the efficiency of the product will be improved, without incurring any obligation to incorporate such improvements in any machines which have been shipped or are in service.

In an effort to continue to improve product quality, SealMaster reserves the right to change specifications without notice.

Any modification or alteration of this machine without prior approval of the manufacturer may void this warranty.

# CRACK PRO 60 & 100

## OPERATING INSTRUCTIONS

1. Check engine oil level-follow manufacturers guidelines as to type and frequency of changes.
  2. Check hydraulic oil level-use grade AW68 hydraulic oil.
  3. Check heat transfer oil level with dipstick #25.-use UNOCAL UNAX RX68 only.  
NEVER CHECK WHEN HOT!
  4. Fill fuel tank with fresh gasoline.NEVER FILL FUEL TANK WITH A LIT BURNER!
  5. Make sure the agitator control valve is in the neutral position.
  6. Open the temperature control box #7,and turn the temperature control knob all the way clockwise to its lowest setting #8.This will prevent the burners from lighting prematurely. Remove burner access door # 31.
  7. Open the LP gas tank valve.
  8. Turn the pilot knob on the gas valve #9 to the pilot position.Light the hand torch #5 and place it in the burner opening .Position it by the pilot light assembly #14, depress the pilot knob and remove the hand torch when you see that the pilot flame is lit.Hold the pilot knob in for at least 30 seconds.Release the knob and turn it to the on position.
  9. Turn the thermostat control to its 500' setting,the burners will now light.
  10. Replace the burner access door..
  11. Open the material tank lid and place inside three boxes of material.Close the lid.
  12. When the material thermometer #16 reaches 300' start the engine and engage the agitator control valve #23 to the forward position.If the agitator will not turn,return the valve to the neutral position,and try again in a few minutes.
  13. When there is a few inches of liquid material in the tank you can add more blocks if desired.**CAUTION: ALWAYS STOP THE AGITATOR WHEN OPENING THE LID FOR ANY REASON.**
  14. As the material temperature gets close to the recommended pouring temperature,you need to turn the temperature control down so that the material temperature and the oil #15 are close together.When constantly adding blocks of material the temperature control should be set about 50' higher than the material pouring temperature.
-

15. If the material temperature starts to climb over the recommended pouring temperature open the lid and add more blocks. Leaving the lid open will also help drop the temperature.

16. Set pour pot or applicator under the pouroff valve #30 and raise the handle to open. **CAUTION; ALWAYS WEAR LONG SLEEVE SHIRT, GLOVES AND A FACE SHIELD WHEN PERFORMING THIS OPERATION !**

17. Fill pour pot to desired level and pour into cracks. Follow with a V-shaped squeegee if desired.

18. To stop for the day perform the following steps:

1. Turn the temperature control knob to its lowest setting, at least a 1/2 hour before completing work..
2. Put agitator control valve in neutral.
3. Shut off engine.
4. Turn off propane tank.

NOTE: Oil temperature must be allowed to cool down to the maximum pouring temperature of the material prior to stopping agitation. If the machine is turned off without allowing cool down time the material could be burned.

---

## CRACK PRO

## PARTS LIST

REF #	ITEM	PART #	QTY
1	TANK CONNECTOR	P933A001	1
2	1/2" L.P.GAS HOSE	P669B007	1
3	HAND TORCH REGULATOR	P735A015	1
4	1/4" L.P.GAS HOSE	P669A005	1
5	HAND TORCH	P75000B010	1
6	MAIN BURNER REGULATOR	P735A034	1
7	TEMPERATURE CONTROL BOX	P941A010	1
8	TEMPERATURE CONTROL	P735A035	1
9	GAS VALVE	P735A036	1
10	1/2" L.P.GAS HOSE	P669B006	2
11	NEEDLE VALVE -OLDER MACHINES	P666A001	2
12	GAS BURNER	P662B030	2
13	THERMOPILE SENSOR	P679A006	1
14	PILOT LIGHT ASS'Y	P735A037	1
15	OIL THERMOMETER	P659A004	1
16	MATERIAL THERMOMETER	P659A009	1
	100 GALLON THERMOMETER	P659A008	1
17	OIL EXPANSION TANK	P75000B005	1
18	TEMPERATURE PROBE ( PART OF TEMP.CONTROL )	N/A	1
19	HYDRAULIC OIL TANK / PUMP	P601A025	1
20	JAW COUPLER	P630A035	2

## CRACK PRO

## PARTS LIST

REF #	ITEM	PART #	QTY
20	JAW COUPLER	P630A032	1
20	COUPLER INSERT	P631A005	1
21	5.5 HP HONDA	P458A027	1
22	FENDER	P549A001	2
23	AGITATOR CONTROL VALVE	P472A004	1
24	OIL OVERFLO PIPE	P75000B006	1
25	OIL DIPSTICK	P75000B001	1
26	AGITATOR DRIVE MOTOR	P474A042	1
27	EXHAUST FLUE	N/A	3
28	OUTER TANK WRAP	N/A	1
29	LOWER AGITATOR BUSHING	P439A004	1
30	MATERIAL POUR OFF VALVE	P585B000	1
31	BURNER ACCESS DOOR	N/A	1
32	TAIL LIGHT	P516A001	2
33	TIRE AND WHEEL ASS'Y	P514A015	2
34	TORSION AXLE	P511A011	1
	AXLE FOR 100 GALLON	P511A012	1
35	PROPANE TANK LATCH	N/A	1
36	PINTLE EYE COUPLER	P646A003	1
37	2 5/16" BALL COUPLER	P553A008	1
38	1 7/8" & 2" BALL COUPLER	P553A006	1
39	MATERIAL TANK LID	N/A	1
40	1/2" HYD.HOSE ASS'Y	N/A	1
41	1/2" HYD.HOSE ASS'Y	N/A	1
42	5/8" HYD.HOSE	N/A	1

CRACK PRO

PARTS LIST

REF #	ITEM	PART #	QTY
43	TRAILER JACK	P551A005	1
44	SAFETY CHAIN	P531A036	2
45	CHAIN HOOK	P517A001	2
46	SPLINE COUPLER	P630A043	1
47	AGITATOR SHAFT	P75000B012	1
	AGITATOR SHAFT / 100 GALLON	P74000B008	1
48	BLADE SUPPORT	N/A	2
49	BLADE	P75000B011	2
50	L.P. TANK HOLDER	N/A	1
51	L.P.TANK / NOT INCLUDED	N/A	1

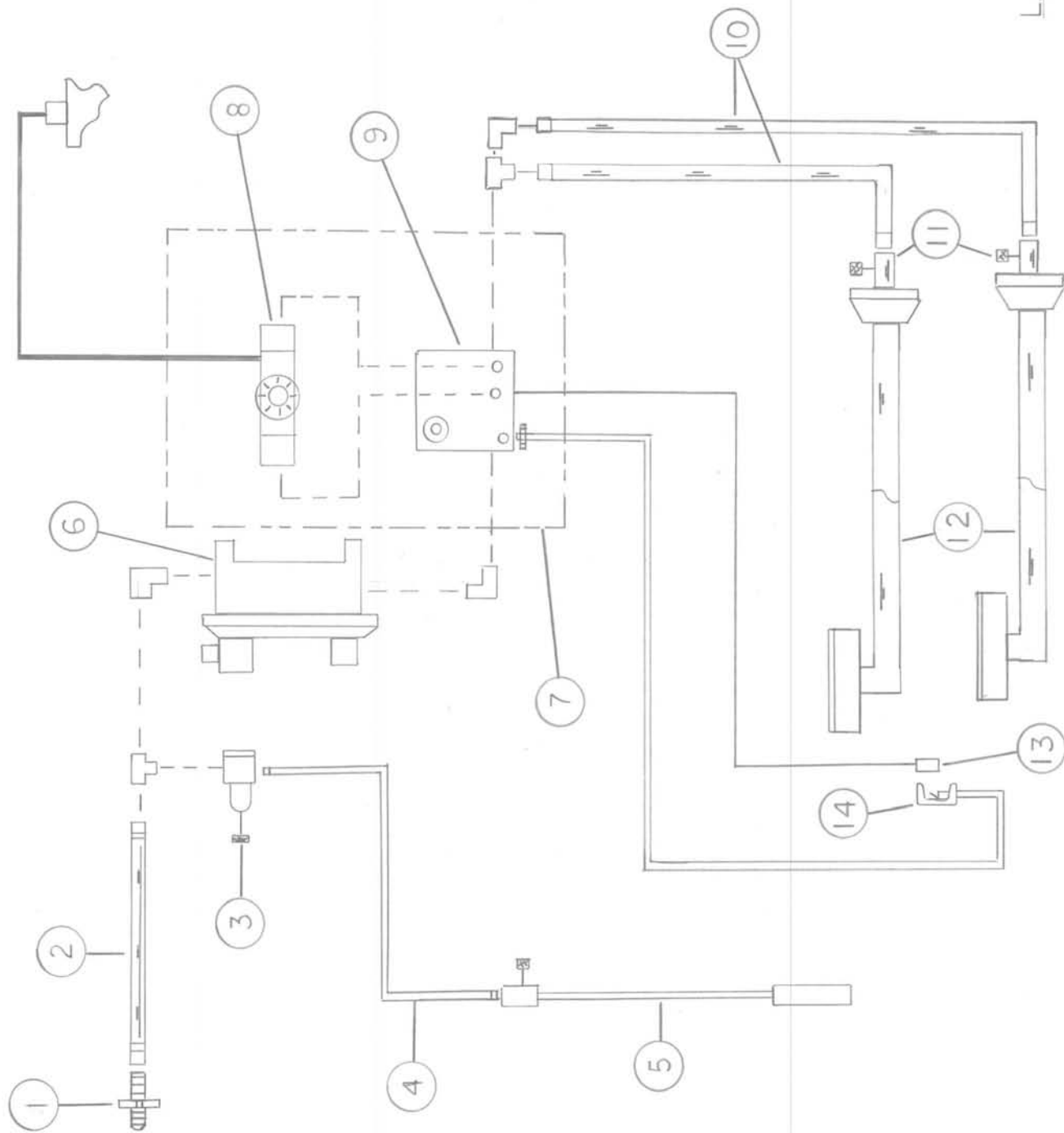

L.P. GAS SCHEMATIC

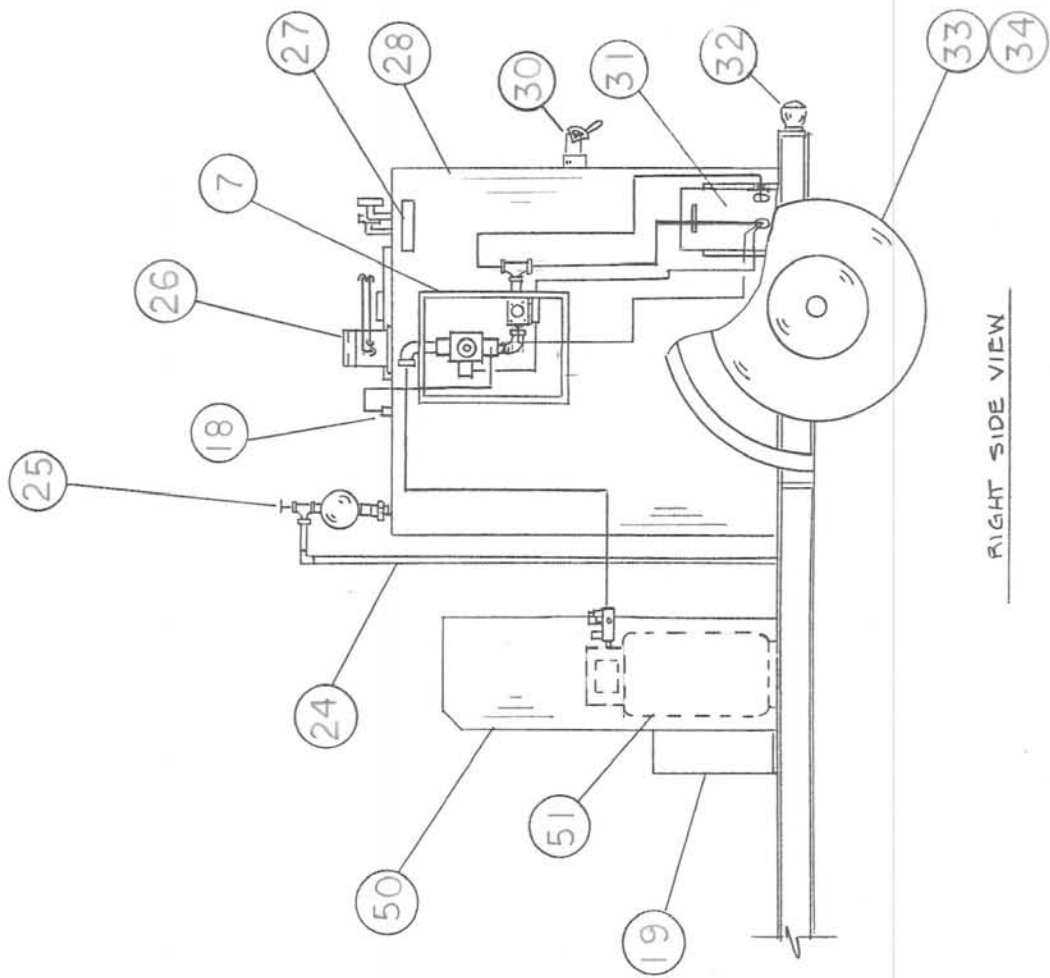

RIGHT SIDE VIEW

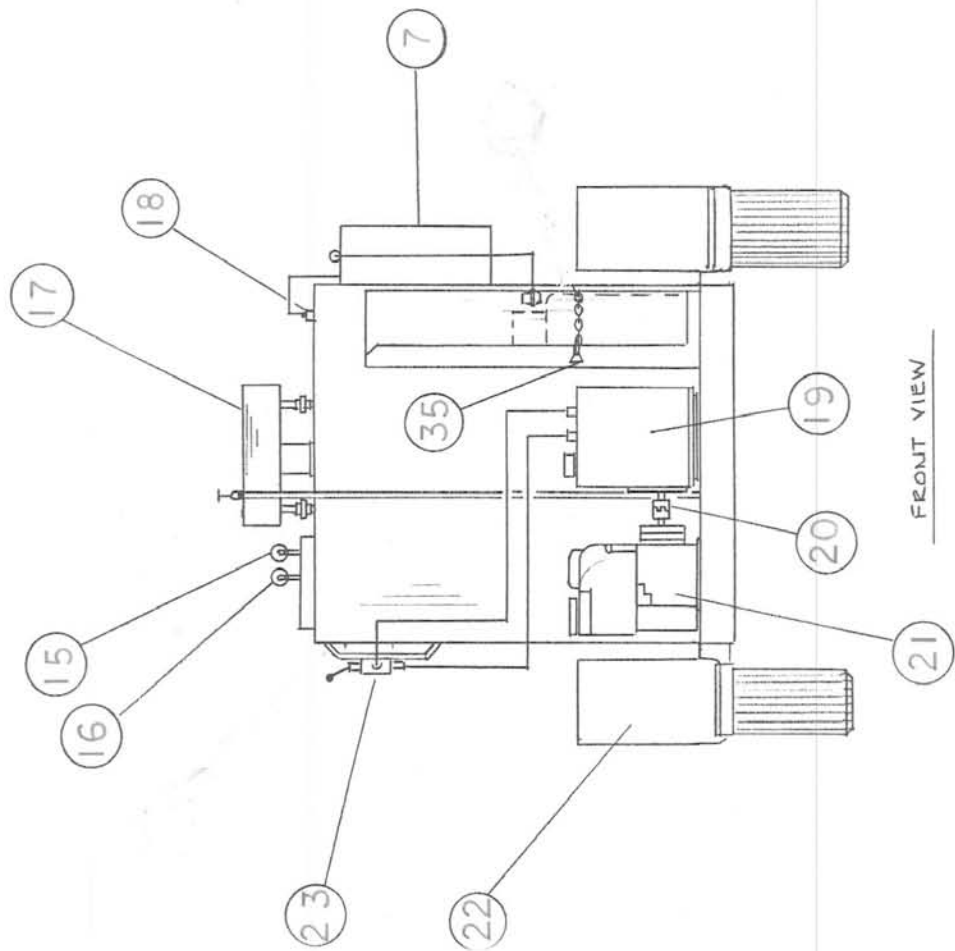

FRONT VIEW

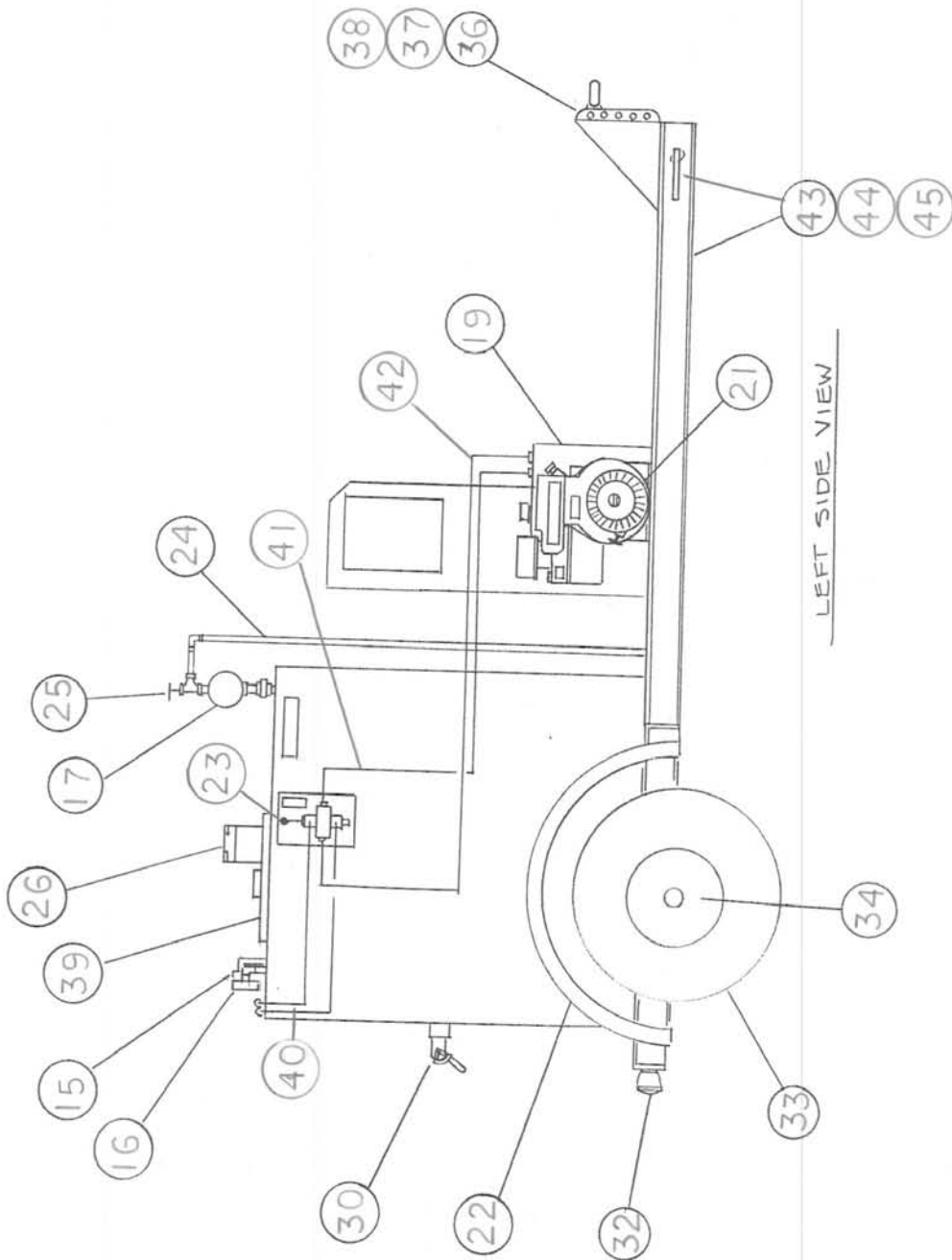

LEFT SIDE VIEW

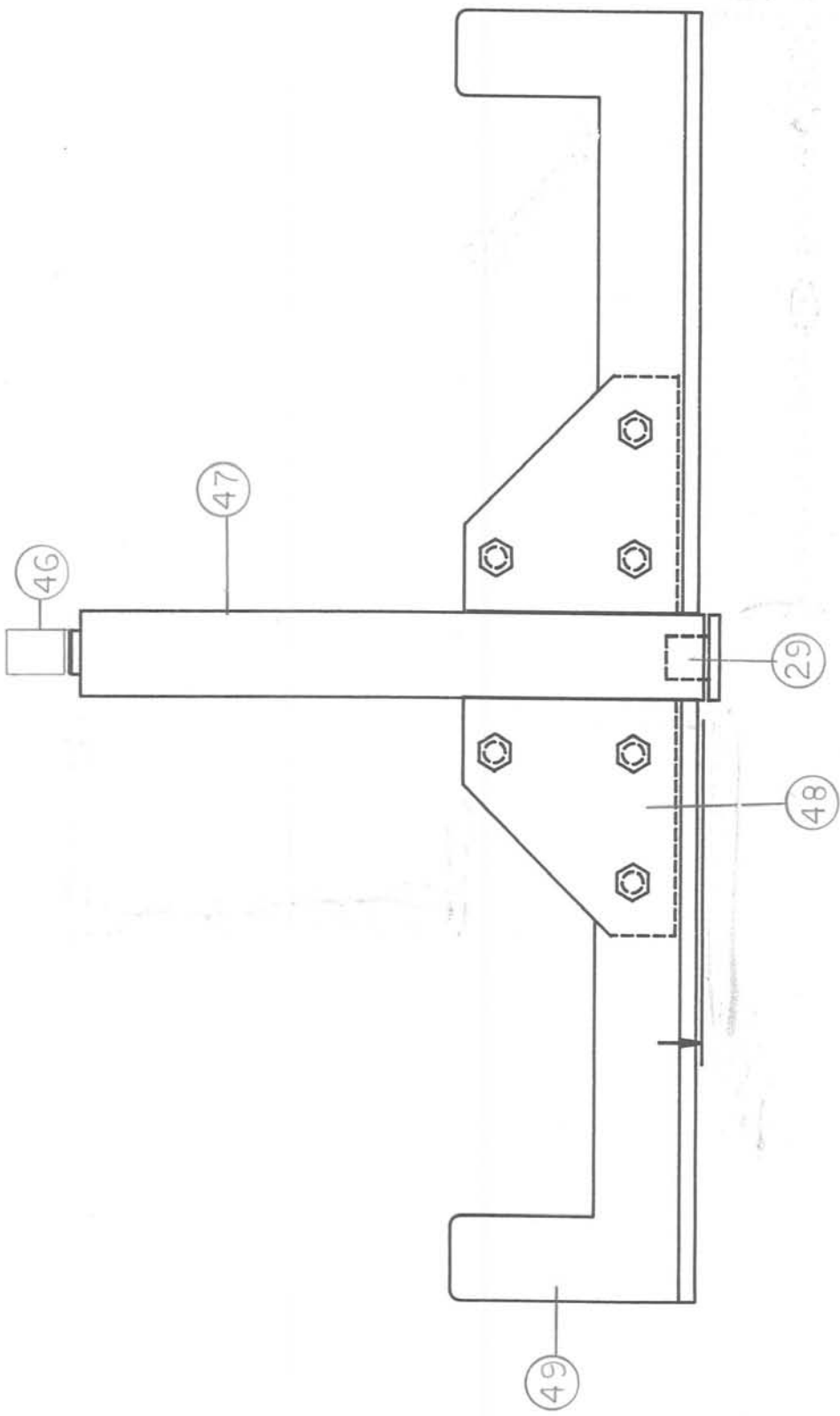

Agitator Assembly



LUBRICANTS

# Product Information

## CITGO A/W HYDRAULIC OILS

**DESCRIPTION:** CITGO A/W Hydraulic Oils are superior antiwear hydraulic and circulating fluids ... specially formulated with high quality base stocks and improved thermally stable additives. These oils offer outstanding resistance to sludge formation, are chemically stable, and exhibit excellent antiwear protection.

**QUALITIES:** CITGO A/W Hydraulic Oils are made from top quality base stocks and contain all the necessary additive components to offer trouble-free service in high-pressure, high-output industrial hydraulic circuits. CITGO A/W Hydraulic Oils have these outstanding properties:

CITGO A/W Hydraulic Oils utilize the latest in thermally stable zinc-type additives. This virtually eliminates the formation of heat-related sludging in sensitive electro-hydraulic servos associated with conventional zinc-type oils. These oils are wholly suitable for N/C machine tools and other high-output equipment where sustained heat is prevalent.

These oils exhibit superior hydrolytic stability in the presence of water and will not contribute to either the formation of metal-etching acids or corrosive reactants.

CITGO A/W Hydraulic Oils are inhibited against rusting in both fresh and sea water and pass both A and B Sequences of the ASTM D 665 Turbine Oil Rust Test.

These oils offer the optimum in antiwear protection to pumps, motors, valves, and other hydraulic circuit components. They are approved against stringent performance requirements including Cincinnati Milacron P-68, P-69 and P-70, Denison HF-O, and Vickers M-2950-S and I-286-S.

CITGO A/W Hydraulic Oils resist foaming and will not foster abnormal air entrainment in properly designed hydraulic circuits. The oils also readily and rapidly separate water permitting sump drain-off of the contaminating water.

**APPLICATIONS:** CITGO A/W Hydraulic Oils are recommended for service in vane, piston, and gear pumps when used in accordance with the manufacturers' recommendations. The oils are designed to provide maximum service life to these pumps as well as to other circuit components such as motors and servos.

CITGO A/W Hydraulic Oils are also recommended for use as gear and bearing lubricant in industrial applications where rust and oxidation inhibited oils are required.

(over)



CITGO A/W All-Temp Hydraulic Oil is a special multigrade antiwear oil for use in mobile equipment where wide temperature ranges are encountered. Its features include pour point depression to -40°F, high viscosity index, resistance to oxidation, foaming and corrosion as well as protection against pump component wear. CITGO A/W All-Temp Hydraulic Oil is highly recommended for use in mobile and other hydraulic equipment in heavy-duty all-weather service. Meets FMC Hi-Performance, Hydraulic Oil, Grade 32 requirements.

CITGO A/W Hydraulic Oils meet the general physical and performance requirements of the European classifications as follows:

DIN 51524 Part 2 (HLP) ISO-VG Grades MV and 22-100.

## TYPICAL PROPERTIES:

### CITGO A/W HYDRAULIC OILS

GRADE	All Temp <sup>(1)</sup>	22	32	46	68	100	150
Commodity Code	33932	33410	33415	33420	33430	33440	33450
Gravity	32.1	31.9	31.3	30.4	29.6	29.0	28.2
Pounds Per Gallon	7.20	7.21	7.24	7.28	7.31	7.34	7.40
Flash Point, °F (°C), COC	439 (226)	433 (223)	414 (212)	468 (242)	464 (240)	475 (246)	471 (244)
Viscosity, cP @ 0°C <sup>(2)</sup>	1170	—	—	—	—	—	—
cSt @ 40°C	30	21.5	32	46	68	98	150
cSt @ 100°C	6.1	4.2	5.5	6.8	8.5	10.9	14
SUS @ 100°F	155	113	171	237	352	514	781
SUS @ 210°F	46	40.5	45	49	55	63	77
Viscosity Index	154	97	100	102	94	94	94
Pour Point, °F (°C)	-40 (-40)	-45 (-43)	-33 (-34)	-27 (-32)	-20 (-29)	+5 (-15)	+5 (-15)
Color, ASTM D 1500	L1.5	L1.0	L1.0	L1.0	L1.5	L3.0	L4.0
Emulsion Test, ASTM D 1401 <sup>(3)</sup>	38-39-3	—	38-39-3	39-40-1	40-40-0	40-40-0	40-40-0
Hydraulic Pump Test, ASTM D 2882 <sup>(4)</sup> 2000 PSI, 100 Hrs., 175°F							
Mgs Ring + Vane Loss	25	—	25	25	28	28	28
Oxidation Test, ASTM D 943, Hrs.	2600	2400	2400	2400	2300	1600	1550
Rust Test, ASTM D 665 A, B <sup>(5)</sup>	Pass	Pass	Pass	Pass	Pass	Pass	Pass
Meets Vickers Requirements M-2950-S <sup>(6)</sup>	Yes	Yes	Yes	Yes	Yes	—	—
Meets Vickers Requirements I-286-S <sup>(7)</sup>	Yes	Yes	Yes	Yes	Yes	—	—
Meets Denison HF-O Requirement	Yes	Yes	Yes	Yes	Yes	Yes	Yes
Meets Cincinnati Milacron Requirement	—	—	P-68	P-70	P-69	—	—
ASTM Grade	150	105	150	215	315	465	700
DIN 51524 Part 2 Grade	HLP (MV)	HLP 22	HLP 32	HLP 46	HLP 68	HLP 100	NA
ISO VG No.	32 <sup>(8)</sup>	22	32	46	68	100	150

Notes: (1) Meets FMC Hi-Performance, Hydraulic Oil, Grade 32 requirements.

(2) ASTM D 2893 Brookfield Viscosity.

(3) 30 minutes max. separation time.

(4) Test utilizes Vickers 104c or 105c vane pump.

(5) Pass - No Rust.

(6) This requirement utilizes Vickers 35VQ25A vane pump test. It is for mobile equipment.

(7) This requirement utilizes Vickers 104c or 105c vane pump test, ASTM D 2882, and is for industrial, stationary systems.

(8) A multigrade, high VI type which may be used in most applications requiring a multiviscosity range of ISO-VG 22, 32, 46.



CITGO Petroleum Corporation  
P.O. Box 3758  
Tulsa, Oklahoma 74102

## Material Safety Data Sheet

Trade Name: CITGO A/W Hydraulic Oil 68  
Commodity Code: 33-430  
Synonyms: Lubricating Oil Date: March 15, 1993  
CAS No.: Mixture Technical Contact: (918) 495-5933  
(Refer to Section 1) Medical Emergency: (918) 495-4700  
Chemtrec Emergency: (800) 424-9300  
Citgo Index No.: 0227

### Material Hazard Evaluation

(Per OSHA Hazard Communication  
Standard [29 CFR Part 1910.1200]) (OHCS)

Health: Final Product Non-Hazardous.

Precautionary Statement: Do not inhale mists or fumes.

HMIS Rating<sup>1</sup>: Health 0 Flammability 1 Reactivity 0

### 1.0 Generic Composition / Components

<u>Components</u>	<u>CAS #</u>	<u>%</u>	<u>Hazard Data</u>
Refined Petroleum Oil(s)	64742-65-0 64741-88-4	> 99	Oral LD50(rat): > 5g/kg
Anti-wear rust and oxidation inhibitor additives (contains Zinc Dialkyldithiophosphate)	Mixture	< 1	LD50(rat): ~2g/kg Skin and eye irritant
Anti-foam Agent	Mixture	< 0.1	Skin, eye and respiratory irritant Ingestion: Hazardous-may be aspirated into the lungs

<sup>1</sup> Hazard Rating: least-0; slight-1; moderate-2; high-3; extreme-4  
Citgo assignment based on our evaluation per NFPA and NPCA guidelines.

## 2.0 Physical Data

Physical Hazard Classification (Per 29 CFR Part 1910.1200)

No	Combustible	No	Flammable	No	Pyrophoric
No	Compressed Gas	No	Organic Peroxide	No	Reactivity
No	Explosive	No	Oxidizer	Yes	Stable

Boiling Point, 760 mmHg, °C(°F): ~ 416(~ 780)  
 Specific Gravity (60/60°F) (H<sub>2</sub>O. = 1): 0.88  
 Vapor Density (Air = 1): > 1  
 % Volatiles by Volume: Negligible  
 Melting Point, °C(°F): NA  
 Vapor Pressure, mmHg (25°C): ND  
 Solubility in H<sub>2</sub>O., % by Weight: Negligible  
 Evaporation Rate (Butyl Acetate = 1): < 1  
 pH of Undiluted Product: NA  
 Appearance and Odor: Amber liquid, slight sulfurized odor.

## 3.0 Fire and Explosion Data

Flash Point, COC, °C(°F)	240(465)
Flash Point, PMC, °C(°F)	221(429)
Fire Point, COC, °C(°F)	265(510)
NFPA Rating <sup>2</sup>	Health: 0 Flammability: 1 Reactivity: 0
Flammable Limits (% by volume in air)	Lower: NA Upper: NA
Extinguishing Media	CO <sub>2</sub> , dry chemical, foam, water fog
Special Fire Fighting Procedure	None.
Unusual Fire or Explosion Hazard	Water may cause frothing.

## 4.0 Reactivity Data

*Stability:* Stable  
*Conditions Contributing to Instability:* None.  
*Incompatibility:* Strong oxidants.  
*Hazardous Decomposition Products:* CO<sub>2</sub>, (CO under incomplete combustion)  
 (thermal, unless otherwise specified) Traces of oxides of S, P, Zn, Ca and Mg.  
*Conditions Contributing to Hazardous Polymerization:* None.

<sup>2</sup> Hazard Rating: least-0; slight-1; moderate-2; high-3; extreme-4  
 Citgo assignment based on our evaluation per NFPA guidelines.

## 5.0 Spill or Leak Procedures

### Procedures if Material is Spilled:

- Remove sources of heat or ignition, provide adequate ventilation, contain leak.
- *Small Spills:* Absorb with suitable material such as rags, straw or sand. Place into containers for later removal.
- *Large Spills:* Contain spill in earthen dikes for later recovery.
- Report spills as required to appropriate authorities.

### Waste Disposal:

- It is the responsibility of the user to determine if the material is a hazardous waste at the time of disposal.
- Check before disposing to be sure you are in compliance with all applicable laws and regulations.
- RCRA Emergency Hotline Number: 800-424-9346.

### Protective Measures During Repair and Maintenance of Contaminated Equipment:

- Refer to Section 7.0 - Special Protection Information.
- Avoid prolonged contact with used oil.
- Wash exposed skin thoroughly with soap and water.
- Remove soiled clothing.
- Use oil impervious gloves if direct contact is expected.

## 6.0 Health Hazard Data

### *Health Hazard Classification*

(Per 29 CFR Part 1910.1200)

No	Carcinogen	No	Corrosive
No	Animal Carcinogen	No	Irritant
No	Suspect Carcinogen	No	Sensitizer
No	Mutagen	No	Teratogen
No	Highly Toxic	No	Target Organ
No	Toxic		

Product listed as Carcinogen or Potential Carcinogen by:

NTP No IARC No OSHA No Other No

Toxicity Summary: General toxicity low.

Major Route(s) of Entry: Inhalation of incidental mists or vapors.

## Acute Exposure Symptoms

<i>Inhalation:</i>	Low risk of inhalation at ambient temperatures. Mists or fumes may cause drowsiness, dizziness, headache, nausea, or lung irritation or chemical pneumonitis.
<i>Dermal Contact:</i>	Transient, slight irritant
<i>Eye Contact:</i>	May be mildly irritating.
<i>Ingestion:</i>	Low toxicity. At a Saybolt viscosity of 350 SUS (100°F), there is still a slight risk of aspiration into the lungs. If a few drops are ingested, material may pass through the system without harm. On ingestion of large quantities, slight GI discomfort, diarrhea, and headache may occur. Lethal dose is about 1 pint for a 150 lb. human adult.
<i>Injection:</i>	Subcutaneous or intramuscular injection may cause irritation, erythema, edema.

## Chronic Exposure

Prolonged and/or frequent contact may cause drying, cracking (dermatitis) or folliculitis.

## Other Special Effects

None expected.

## Medical Conditions Aggravated by Exposure

None.

## First Aid and Emergency Procedures for Acute Effect

<i>Inhalation:</i>	Remove to fresh air. Respiratory support, if necessary. Seek medical aid.
<i>Dermal:</i>	Wash with soap and water. Do not wear heavily contaminated clothing before laundering.
<i>Eyes:</i>	Flush with large volumes of water. Seek physician if any complications arise.
<i>Ingestion:</i>	Induce vomiting. Seek medical aid.
<i>Injection:</i>	Subcutaneous injection is a medical emergency. Seek medical aid immediately.

**Notes to Physician:** Following ingestion at a viscosity of about 350 SUS (100°F), there may be a slight risk of aspiration into the lungs. Emesis may be considered. Subcutaneous or intramuscular injection requires prompt surgical debridement. If not familiar with technique, seek skilled advice.

## 7.0 Special Protection Information

**Ventilation Requirements:** Use in well ventilated area. In confined space, mechanical ventilation may be required to keep levels of certain components below mandated standards as evaluated by designated personnel.

**Permitted Threshold Air Concentrations:**

Mineral Oil Mist	TLV-TWA	5 mg/m <sup>3</sup>	OSHA-PEL	5 mg/m <sup>3</sup>
	TLV-STEL	10 mg/m <sup>3</sup>	OSHA-STEL	ND
	TLV-Ceiling	ND	OSHA-Ceiling	ND
			OSHA-Peak	ND

**Specific Personal Protective Equipment:**

**Respiratory:** Normally none required. If high vapor or mist concentrations expected, use respirator approved for organic vapors and mists.

**Eyes:** Safety goggles, or chemical splash goggles if splashing is anticipated.

**Dermal:** Oil impervious gloves if frequent or prolonged contact is expected.

**Other Clothing or Equipment:** Wear body-covering work clothes to avoid prolonged or repeated exposure. Launder soiled work clothes before reuse.

## 8.0 Transportation and Special Precautions

**Storage:** Do not apply high heat or flame to container. Keep separate from strong oxidizing agents.

**Caution:** Empty containers may contain product residue which could include flammable or explosive vapors.

Consult appropriate Federal, State and Local authorities before reusing, reconditioning, reclaiming, recycling or disposing of empty containers and/or waste residues of this product.

### *DOT Information*

Proper Shipping Name:	Petroleum Lubricating Oil.
Hazard Class:	Non-Hazardous.
Hazard Identification Number:	None assigned.
Placard:	None.
Compatibility Category:	Group 33.
CHRIS Code:	OMN



## 10.0 Labeling

**NOTE**

*This product has been determined not to be a physical or a health hazard as defined by the OSHA Hazard Communication Standard.*

---

ALL STATEMENTS, INFORMATION, AND DATA PROVIDED IN THIS MATERIAL SAFETY DATA SHEET ARE BELIEVED TO BE ACCURATE AND RELIABLE, BUT ARE PRESENTED WITHOUT GUARANTEE, REPRESENTATION, WARRANTY, OR RESPONSIBILITY OF ANY KIND, EXPRESSED OR IMPLIED. ANY AND ALL REPRESENTATIONS AND/OR WARRANTIES OF MERCHANTABILITY OR FITNESS FOR A PARTICULAR PURPOSE ARE SPECIFICALLY DISCLAIMED. USERS SHOULD MAKE THEIR OWN INVESTIGATIONS TO DETERMINE THE SUITABILITY OF THE INFORMATION OR PRODUCTS FOR THEIR PARTICULAR PURPOSE. NOTHING CONTAINED HEREIN IS INTENDED AS PERMISSION, INDUCEMENT, OR RECOMMENDATION TO VIOLATE ANY LAWS OR TO PRACTICE ANY INVENTION COVERED BY EXISTING PATENTS, COPYRIGHTS OR INVENTIONS.

---

NA - Not Applicable

ND - No Data

NE - Not Established

**PRODUCT-APPLICATION SHEET**

# Unax RX

## PRODUCT DESCRIPTION

Unax RX is a premium quality oil designed for use in hydraulic systems, steam turbines, circulating lubrication systems, industrial gear sets, air compressors, heat exchange systems, and a wide variety of other industrial applications.

Unax RX is an inhibited oil. It has good oxidation resistance to minimize sludge and gum formation to provide good service life. Unax RX protects the metal surfaces of system components against rust and corrosion. It possesses good water separating characteristics, thus minimizing emulsions. Unax RX is resistant to foaming and foam build-up caused by excessive air drawn into the system.

## RECOMMENDED FOR:

Cincinnati Milacron:  
 Rust and Oxidation inhibited Hydraulic Oils  
 P-38 ISO 32, P-55 ISO 46  
 P-54 ISO 68, P-57 ISO 150  
 Denison Specification HF-1 for Piston Pump Lubricants.  
 Denison, Sunstrand and Vickers hydrostatic transmissions.  
 General Electric GEK-28143-A  
 USX requirement 120 & 125 (Grades 22, 32, 46, 68)  
 Westinghouse I.L. 1250-4710-B

## TYPICAL INSPECTION TESTS:

Grade, ISO	22	32	46	68	100	150	220
Former ASTM	105	150	215	315	465	700	1000
AGMA Grades	-	-	1	2	3	4	5
Product Code	4610	4611	4612	4613	4614	4615	4616
Density, g/cm <sup>3</sup> @ 15°C	0.863	0.870	0.875	0.881	0.884	0.888	0.890
Gravity, °API	32.5	31.1	30.2	29.1	28.6	27.9	27.5
Flash Point, COC, °C (°F)	210 (410)	216 (421)	230 (446)	240 (464)	242 (468)	244 (471)	284 (543)
Pour Point, COC, °C (°F)	-27 (-17)	-30 (-22)	-18 (0)	-18 (0)	-12 (10)	-15 (5)	-12 (10)
Viscosity							
cSt @ 40°C	21.9	32.2	45.8	67.0	99.7	149	218
cSt @ 100°C	4.33	5.46	6.81	8.64	11.1	14.6	19.0
SUS @ 100°F	115	166	236	349	521	783	1152
SUS @ 210°F	40.8	44.6	49.1	55.4	64.3	78.1	96.8
Viscosity Index	98	101	103	100	97	96	97
Aniline Point, °C (°F)	98 (208)	101 (214)	103 (217)	105 (221)	110 (230)	114 (237)	118 (244)
Acid No. mg KOH/g	0.01	0.01	0.01	0.01	0.01	0.01	0.01
Carbon Resid. Rams wt%	0.10	0.10	0.10	0.10	0.10	0.10	0.20
Foam Test ASTM D892 stability @ 5 Min ml @ 24/93/24°C	0/0/0	0/0/0	0/0/0	0/0/0	0/0/0	0/0/0	0/0/0
Demulsibility, ASTM D1401, Minutes to pass							
@ 54.5°C	< 10	< 10	< 10	< 10	-	-	-
@ 82°C	-	-	-	-	< 15	< 15	< 15
Copper Corrosion 3 hrs @ 100°C	Pass	Pass	Pass	Pass	Pass	Pass	Pass
Rust Test ASTM D665 A&B	Pass	Pass	Pass	Pass	Pass	Pass	Pass

MATERIAL SAFETY DATA SHEET



1201 West 5th Street  
Los Angeles, California 90017

Product Name: UNOCAL UNAX RX 68  
Product Code No: 04613  
Page 1  
Issue Date: 10/09/91  
Status: FINAL

Responsible Party:  UNOCAL REFINING & MARKETING DIVISION UNION OIL COMPANY OF CALIFORNIA 1201 WEST 5TH STREET LOS ANGELES, CALIFORNIA 90017  CONTACT FOR FURTHER INFORMATION: MSDS COORDINATOR 213-977-7589	Transportation Emergencies: CHEMTREC (800) 424-9300 Cont. U.S. (202) 483-7616 (Collect) from Alaska & Hawaii Health Emergencies: LOS ANGELES POISON CONTROL CENTER (24 hrs) (800) 356-3129
---	--

PRODUCT IDENTIFICATION

PRODUCT NAME: UNOCAL UNAX RX 68  
 GENERIC NAME: INDUSTRIAL OIL  
 CHEMICAL FAMILY: PETROLEUM HYDROCARBON  
 DOT PROPER SHIPPING NAME: NOT APPLICABLE  
 ID NUMBER: NONE  
 DOT HAZARD CLASSIFICATION: NOT REGULATED

PRECAUTIONARY WARNING

LIQUID OR VAPOR MAY IGNITE. KEEP AWAY FROM ALL SOURCES OF IGNITION. DO NOT PRESSURIZE, CUT, WELD, BRAZE, SOLDER, GRIND OR DRILL ON OR NEAR CONTAINER. "EMPTY" CONTAINER RETAINS RESIDUE (LIQUID AND/OR VAPOR) AND MAY EXPLODE IN HEAT OF A FIRE.

SECTION I - COMPONENTS

COMPONENTS	PERCENT	EXPOSURE LIMIT	UNITS	AGENCY	TYPE
<b>HAZARDOUS COMPONENTS</b>					
OIL MIST, IF GENERATED					
CAS #: 8012-95-1		5.000	mg/m3	ACGIH	TWA
		10.000	mg/m3	ACGIH	STEL
		5.000	mg/m3	MSHA	TWA
		1.000	mg/m3	OSHA	TWA
		5.000	mg/m3	OSHA	TWA
		5.000	mg/m3	CAL OSHA	TWA
<b>OTHER COMPONENTS</b>					
SOLVENT DEWAXED DISTILLATE, HEAVY PARAFFIN					
CAS #: 64742-65-0	0-99%	(SEE OIL MIST EXPOSURE LIMIT)			
HYDROTREATED DISTILLATE, HEAVY PARAFFIN					
CAS #: 64742-54-7	0-99%	(SEE OIL MIST EXPOSURE LIMIT)			

Product Name: UNOCAL UNAX RX 68 Product Code No: 04613	UNION OIL CO. Page 2 Issue Date: 10/09/91 Status: FINAL
---	--

SECTION I - COMPONENTS	PERCENT	EXPOSURE LIMIT	UNITS AGENCY	TYPE
TRADE SECRET CAS #: PROPRIETARY	0-1%			NOT ESTABLISHED
THIS PRODUCT CONTAINS THE FOLLOWING CHEMICALS SUBJECT TO THE REPORTING REQUIREMENTS OF SARA 313 AND 40 CFR 372:				
			CAS NUMBER	WEIGHT %
	--NONE--			---

SECTION II - EMERGENCY AND FIRST AID PROCEDURES \*\*\*EMERGENCY\*\*\*  
 Have physician call LOS ANGELES POISON CONTROL CENTER (24 hrs) (800) 356-3129

**EYE CONTACT:**  
 IF IRRITATION OR REDNESS DEVELOPS, MOVE VICTIM AWAY FROM EXPOSURE AND INTO FRESH AIR. FLUSH EYES WITH CLEAN WATER. IF SYMPTOMS PERSIST, SEEK MEDICAL ATTENTION.

**SKIN CONTACT:**  
 WIPE MATERIAL FROM SKIN AND REMOVE CONTAMINATED SHOES AND CLOTHING. CLEANSE AFFECTED AREA(S) THOROUGHLY BY WASHING WITH MILD SOAP AND WATER AND, IF NECESSARY, A WATERLESS SKIN CLEANSER. IF IRRITATION OR REDNESS DEVELOPS AND PERSISTS, SEEK MEDICAL ATTENTION.

**INHALATION (BREATHING):**  
 IF RESPIRATORY SYMPTOMS DEVELOP, MOVE VICTIM AWAY FROM SOURCE OF EXPOSURE AND INTO FRESH AIR. IF SYMPTOMS PERSIST, SEEK MEDICAL ATTENTION. IF VICTIM IS NOT BREATHING, IMMEDIATELY BEGIN ARTIFICIAL RESPIRATION. IF BREATHING DIFFICULTIES DEVELOP, OXYGEN SHOULD BE ADMINISTERED BY QUALIFIED PERSONNEL. SEEK IMMEDIATE MEDICAL ATTENTION.

**INGESTION (SWALLOWING):**  
 NO FIRST AID IS NORMALLY REQUIRED; HOWEVER, IF SWALLOWED, AND SYMPTOMS DEVELOP, SEEK MEDICAL ATTENTION.

**COMMENTS:**  
 NOTE TO PHYSICIANS: ACUTE ASPIRATION OF LARGE AMOUNTS OF OIL LADEN MATERIAL MAY PRODUCE A SERIOUS ASPIRATION PNEUMONIA. PATIENTS WHO ASPIRATE THESE OILS SHOULD BE FOLLOWED FOR THE DEVELOPMENT OF LONG-TERM SEQUELAE. REPEATED ASPIRATION OF SMALL QUANTITIES OF MINERAL OIL CAN PRODUCE CHRONIC INFLAMMATION OF THE LUNGS (i.e. LIPOID PNEUMONIA) THAT MAY PROGRESS TO PULMONARY FIBROSIS. SYMPTOMS OFTEN ARE SUBTLE AND RADIOLOGICAL CHANGES APPEAR WORSE THAN CLINICAL ABNORMALITIES. OCCASIONALLY, PERSISTENT COUGH, IRRITATION OF THE UPPER RESPIRATORY TRACT, SHORTNESS OF BREATH WITH EXERTION, FEVER AND BLOODY SPUTUM OCCUR. INHALATION EXPOSURE TO OIL MISTS BELOW CURRENT WORKPLACE EXPOSURE LIMITS IS UNLIKELY TO CAUSE PULMONARY ABNORMALITIES.

SECTION III - HEALTH HAZARDS/ROUTES OF ENTRY

**EYE CONTACT:**  
 THIS MATERIAL MAY CAUSE MILD EYE IRRITATION. DIRECT CONTACT WITH THE LIQUID OR EXPOSURE TO MISTS MAY CAUSE STINGING, TEARING AND REDNESS.

**SKIN CONTACT:**  
 THIS MATERIAL MAY CAUSE MILD SKIN IRRITATION. PROLONGED OR REPEATED CONTACT OR EXPOSURE TO MISTS MAY CAUSE REDNESS, BURNING, AND DRYING AND CRACKING OF THE SKIN. NO HARMFUL EFFECTS ARE EXPECTED FROM SKIN ABSORPTION OF THIS MATERIAL. PERSONS WITH PRE-EXISTING SKIN DISORDERS MAY BE MORE SUSCEPTIBLE TO THE EFFECTS OF THIS MATERIAL.

UNION OIL CO.

Product Name: UNOCAL UNAX RX 68  
Product Code No: 04613

Page 3  
Issue Date: 10/09/91  
Status: FINAL

**SECTION III - HEALTH HAZARDS/ROUTES OF ENTRY****INHALATION (BREATHING):**

BREATHING HIGH CONCENTRATIONS OF MISTS MAY CAUSE IRRITATION OF THE NOSE, THROAT AND RESPIRATORY TRACT.

**INGESTION (SWALLOWING):**

NO HARMFUL EFFECTS HAVE BEEN DEMONSTRATED IN ORAL TOXICITY STUDIES. HOWEVER, INGESTION OF EXCESSIVE QUANTITIES OF THIS MATERIAL MAY CAUSE IRRITATION OF THE DIGESTIVE TRACT.

**COMMENTS:**

THIS MATERIAL HAS NOT BEEN IDENTIFIED AS A CARCINOGEN BY NTP, IARC OR OSHA.

**SECTION IV - SPECIAL PROTECTION INFORMATION****VENTILATION:**

IF CURRENT VENTILATION PRACTICES ARE NOT ADEQUATE TO MAINTAIN AIRBORNE CONCENTRATIONS BELOW THE ESTABLISHED EXPOSURE LIMITS (SEE SECTION I), ADDITIONAL VENTILATION OR EXHAUST SYSTEMS MAY BE REQUIRED.

**RESPIRATORY PROTECTION:**

IF AIRBORNE CONCENTRATIONS EXCEED ESTABLISHED EXPOSURE LIMITS (SEE SECTION I), A SUITABLE FILTER TYPE RESPIRATOR SHOULD BE WORN.

**PROTECTIVE GLOVES:**

THE USE OF GLOVES IMPERMEABLE TO THE SPECIFIC MATERIAL HANDLED IS ADVISED TO PREVENT SKIN CONTACT AND POSSIBLE IRRITATION.

**EYE PROTECTION:**

APPROVED EYE PROTECTION TO SAFEGUARD AGAINST POTENTIAL EYE CONTACT, IRRITATION OR INJURY IS RECOMMENDED.

**OTHER PROTECTIVE EQUIPMENT:**

IT IS SUGGESTED THAT A SOURCE OF CLEAN WATER BE AVAILABLE IN THE WORK AREA FOR FLUSHING EYES AND SKIN. IMPERVIOUS CLOTHING SHOULD BE WORN AS NEEDED.

**SECTION V - REACTIVITY DATA****REACTIVITY:**

STABLE UNDER NORMAL CONDITIONS OF STORAGE AND HANDLING.

**CONDITIONS AFFECTING REACTIVITY:**

EXTENDED EXPOSURE TO HIGH TEMPERATURES MAY CAUSE DECOMPOSITION.

**INCOMPATIBLE MATERIALS:**

AVOID CONTACT WITH STRONG OXIDIZING AGENTS.

**HAZARDOUS DECOMPOSITION PRODUCTS:**

COMBUSTION MAY YIELD MAJOR AMOUNTS OF OXIDES OF CARBON AND MINOR AMOUNTS OF OXIDES OF SULFUR AND NITROGEN.

UNION OIL CO.

Product Name: UNOCAL UNAX RX 68  
Product Code No: 04613

Page 4  
Issue Date: 10/09/91  
Status: FINAL

## SECTION V - REACTIVITY DATA

HAZARDOUS POLYMERIZATION:

WILL NOT OCCUR

POLYMERIZATION CONDITIONS TO AVOID:

NONE KNOWN

SECTION VI - SPILL AND LEAK PROCEDURES \*\*\*HIGHWAY OR RAILWAY SPILLS\*\*\*  
Call CHEMTREC (800) 424-9300 Cont. U.S.  
(Collect) (202) 483-7616 from Alaska & Hawaii

PRECAUTIONS IN CASE OF RELEASE OR SPILL:

MAY IGNITE. KEEP ALL SOURCES OF IGNITION AWAY FROM SPILL/RELEASE. STAY UPWIND AND AWAY FROM SPILL/RELEASE. ISOLATE HAZARD AREA AND LIMIT ENTRY TO AUTHORIZED PERSONNEL. STOP SPILL/RELEASE IF IT CAN BE DONE WITHOUT RISK. WEAR APPROPRIATE PROTECTIVE EQUIPMENT INCLUDING RESPIRATORY PROTECTION AS CONDITIONS WARRANT (SEE SECTION IV). PREVENT SPILLED MATERIAL FROM ENTERING SEWERS, STORM DRAINS, OTHER UNAUTHORIZED TREATMENT DRAINAGE SYSTEMS AND NATURAL WATERWAYS. DIKE FAR AHEAD OF SPILL FOR LATER RECOVERY OR DISPOSAL. SPILLED MATERIAL MAY BE ABSORBED INTO AN APPROPRIATE ABSORBENT MATERIAL. NOTIFY FIRE AUTHORITIES AND APPROPRIATE FEDERAL, STATE AND LOCAL AGENCIES. IMMEDIATE CLEANUP OF ANY SPILL IS RECOMMENDED. IF SPILL OF ANY AMOUNT IS MADE INTO OR UPON U.S. NAVIGABLE WATERS, THE CONTIGUOUS ZONE, OR ADJOINING SHORELINES, NOTIFY THE NATIONAL RESPONSE CENTER (PHONE NUMBER 800-424-8802).

WASTE DISPOSAL METHOD:

DISPOSE OF PRODUCT IN ACCORDANCE WITH LOCAL, COUNTY, STATE, AND FEDERAL REGULATIONS.

## SECTION VII - STORAGE AND SPECIAL PRECAUTIONS

HANDLING AND STORAGE PRECAUTIONS:

USE AND STORE THIS MATERIAL IN COOL, DRY, WELL VENTILATED AREAS AWAY FROM HEAT AND ALL SOURCES OF IGNITION. KEEP CONTAINER(S) CLOSED. STORE ONLY IN APPROVED CONTAINERS. KEEP AWAY FROM ANY INCOMPATIBLE MATERIALS (SEE SECTION V). PROTECT CONTAINER(S) AGAINST PHYSICAL DAMAGE. DO NOT ENTER CONFINED SPACES SUCH AS TANKS OR PITS WITHOUT FOLLOWING PROPER ENTRY PROCEDURES SUCH AS ASTM D-4276. THE USE OF RESPIRATORY PROTECTION IS ADVISED WHEN CONCENTRATIONS EXCEED ANY ESTABLISHED EXPOSURE LIMITS (SEE SECTIONS I AND IV). WASH THOROUGHLY AFTER HANDLING. DO NOT WEAR CONTAMINATED CLOTHING OR SHOES. USE GOOD PERSONAL HYGIENE PRACTICE. "EMPTY" CONTAINERS RETAIN RESIDUE (LIQUID AND/OR VAPOR) AND CAN BE DANGEROUS. DO NOT PRESSURIZE, CUT, WELD, BRAZE, SOLDER, DRILL, GRIND OR EXPOSE SUCH CONTAINERS TO HEAT, FLAME, SPARKS OR OTHER SOURCES OF IGNITION; THEY MAY EXPLODE AND CAUSE INJURY OR DEATH. "EMPTY" DRUMS SHOULD BE COMPLETELY DRAINED, PROPERLY BUNGED AND PROMPTLY SHIPPED TO THE SUPPLIER OR A DRUM RECONDITIONER. ALL OTHER CONTAINERS SHOULD BE DISPOSED OF IN AN ENVIRONMENTALLY SAFE MANNER AND IN ACCORDANCE WITH GOVERNMENTAL REGULATIONS. BEFORE WORKING ON OR IN TANKS WHICH CONTAIN OR HAVE CONTAINED THIS PRODUCT, REFER TO OCCUPATIONAL SAFETY AND HEALTH ADMINISTRATION REGULATIONS, ANSI Z49.1, AND OTHER GOVERNMENTAL AND INDUSTRIAL REFERENCES PERTAINING TO CLEANING, REPAIRING, WELDING, OR OTHER CONTEMPLATED OPERATIONS.

## SECTION VIII - FIRE AND EXPLOSION HAZARD DATA

NFPA HAZARD CLASS	HEALTH HAZARD:	1	HAZARD RANKING	FLASH POINT  439 F (COC) 226 C
	FLAMMABILITY:	1	0 = LEAST	
	REACTIVITY:	0	1 = SLIGHT	
	OTHER:		2 = MODERATE	
			3 = HIGH	
			4 = EXTREME	

UNION OIL CO.

Product Name: UNOCAL UNAX RX 68  
Product Code No: 04613

Page 5  
Issue Date: 10/09/91  
Status: FINAL

SECTION VIII - FIRE AND EXPLOSION HAZARD DATA

EXTINGUISHING MEDIA:

DRY CHEMICAL, CARBON DIOXIDE, HALON, FOAM OR WATER SPRAY IS RECOMMENDED.

UNUSUAL FIRE & EXPLOSION HAZARDS:

THIS MATERIAL MAY BURN, BUT WILL NOT IGNITE READILY. IF CONTAINER IS NOT PROPERLY COOLED, IT MAY EXPLODE IN THE HEAT OF A FIRE. VAPORS ARE HEAVIER THAN AIR AND MAY ACCUMULATE IN LOW AREAS.

SPECIAL FIRE FIGHTING PROCEDURES:

WEAR APPROPRIATE PROTECTIVE EQUIPMENT INCLUDING RESPIRATORY PROTECTION AS CONDITIONS WARRANT (SEE SECTION IV). STOP SPILL/RELEASE IF IT CAN BE DONE WITHOUT RISK. MOVE UNDAMAGED CONTAINERS FROM FIRE AREA IF IT CAN BE DONE WITHOUT RISK. WATER SPRAY MAY BE USEFUL IN MINIMIZING OR DISPERSING VAPORS AND COOLING EQUIPMENT EXPOSED TO HEAT AND FLAME. AVOID SPREADING BURNING LIQUID WITH WATER USED FOR COOLING PURPOSES.

SECTION IX - PHYSICAL DATA

\*\*\*UNLESS OTHERWISE NOTED, VALUES ARE AT  
20 C/68 F AND 760 mm Hg/1 atm.

<u>APPROX BOILING POINT</u>	(AIR = 1) <u>VAPOR DENSITY</u>	(N-BUTYL ACETATE = 1) <u>EVAPORATION RATE</u>	<u>% VOLATILE</u>
>600 F / 316 C	>1	<1	NEGLIGIBLE
<u>% SOLUBILITY IN WATER</u>	<u>VAPOR PRESSURE (MM HG)</u>		
NEGLIGIBLE	NOT DETERMINED		
<u>SPECIFIC GRAVITY</u>			
0.88 @ 15 C			
<u>APPEARANCE</u>			
CLEAR, YELLOW LIQUID			
<u>ODOR</u>			
CHARACTERISTIC PETROLEUM			
<u>VISCOSITY</u>			
67 cSt @ 40 C			

SECTION X - DOCUMENTARY INFORMATION

ISSUE DATE: 10/09/91 PRODUCT CODE NO. 04613  
PREV. DATE: 07/03/90 PREV. PROD. CODE NO. NONE  
MSDS NO: NONE PREV. MSDS NO: NONE

UNION OIL CO.

Product Name: UNOCAL UNAX RX 68  
Product Code No: 04613

Page 6  
Issue Date: 10/09/91  
Status: FINAL

SECTION X - DOCUMENTARY INFORMATION

DISCLAIMER OF EXPRESSED AND IMPLIED WARRANTIES

The information in this document is believed to be correct as of the date issued. HOWEVER, NO WARRANTY OF MERCHANTABILITY, FITNESS FOR ANY PARTICULAR PURPOSE, OR ANY OTHER WARRANTY IS EXPRESSED OR IS TO BE IMPLIED REGARDING THE ACCURACY OR COMPLETENESS OF THIS INFORMATION, THE RESULTS TO BE OBTAINED FROM THE USE OF THIS INFORMATION OR THE PRODUCT, THE SAFETY OF THIS PRODUCT, OR THE HAZARDS RELATED TO ITS USE. This information and product are furnished on the condition that the person receiving them shall make his own determination as to the suitability of the product for his particular purpose and on the condition that he assume the risk of his use thereof.

\* \* \* \* \* THIS IS THE LAST PAGE \* \* \* \* \*  
\* \* \* \* \* THIS IS THE LAST PAGE \* \* \* \* \*  
\* \* \* \* \* THIS IS THE LAST PAGE \* \* \* \* \*

**DIESEL**

**BURNER**

**SUPPLEMENT**

# Crack Pro<sup>®</sup>

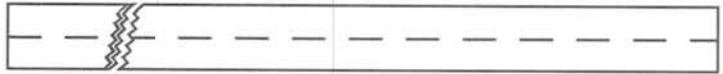

ThorWorks Industries, Inc.  
Sandusky, Ohio  
(419) 626-4375

## TEMPERATURE CONTROL

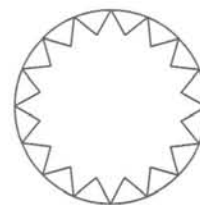
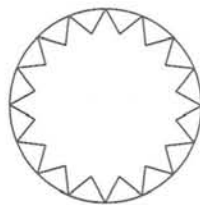
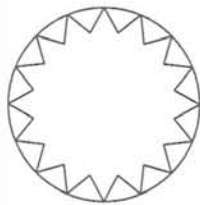
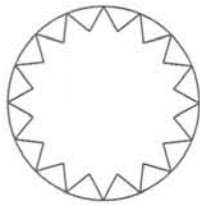
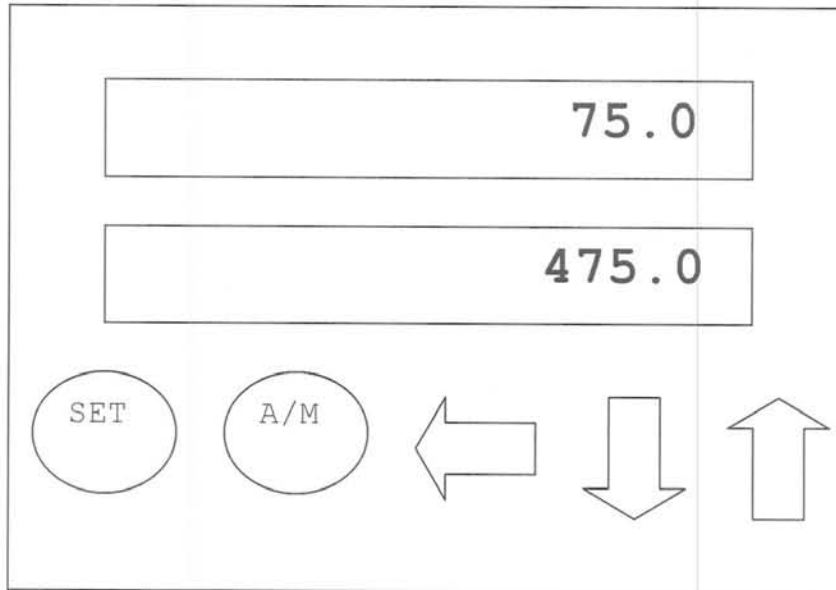

CONT PWR    BURNER ENABLE    HI TEMP    RESET

The top scale is the current temperature of the heat transfer oil. The bottom scale is the temperature that you want the oil to be heated to. The burner shuts off when your setting is exceeded by 10 degrees. It comes back on when the oil drops to 10 degrees under your setting. The sequence for setting the temperature is: Press the left arrow 3 times, then press up or down to get the 4, press the left arrow again, then up or down for the 7, press the left arrow again, then up or down for the 5, then press SET.

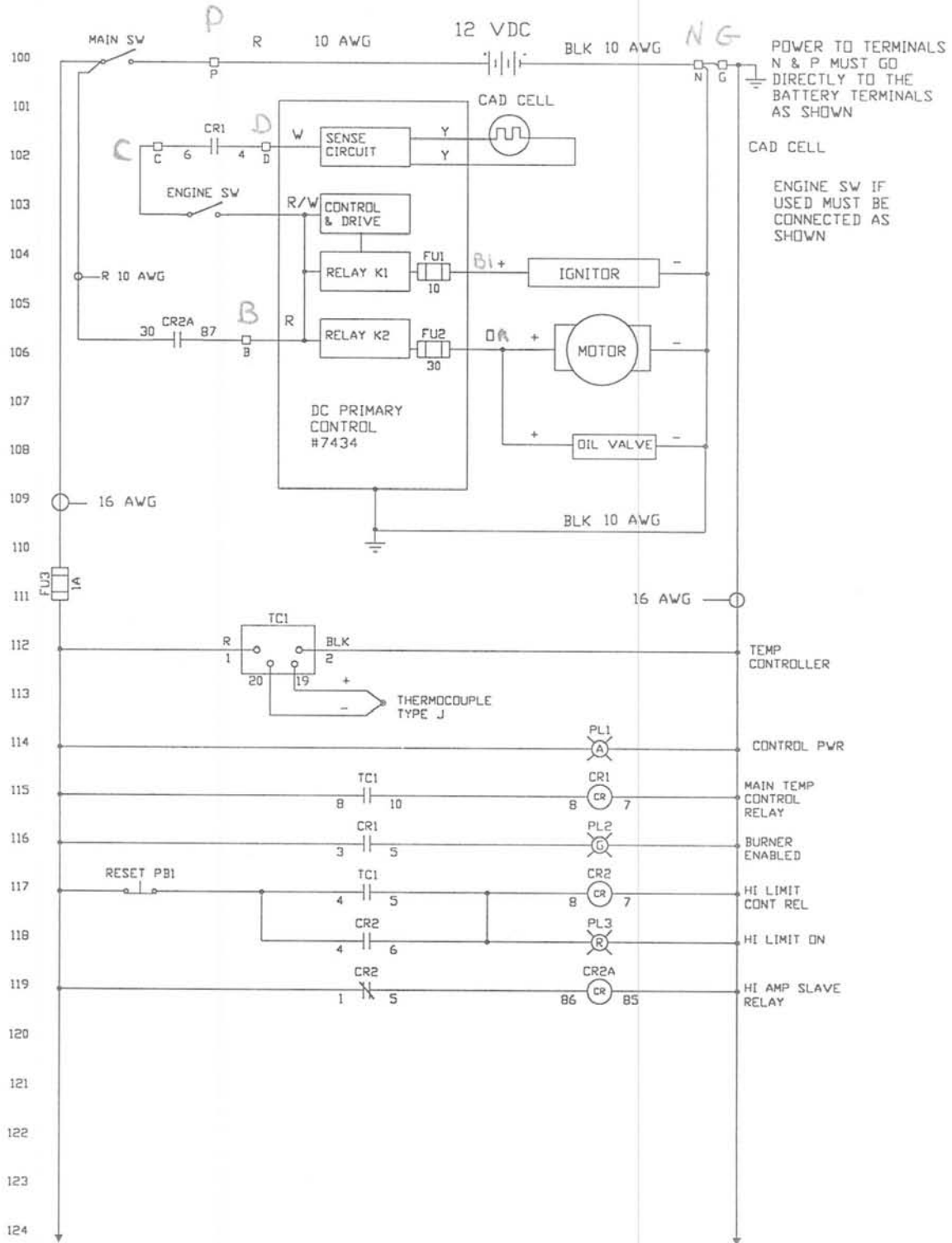

### TERMINALS

P - BATTERY POSITIVE 10ga. WIRE  
 B - RED WIRE IN BURNER  
 N - BATTERY NEGATIVE 10ga. WIRE  
 G - BLACK WIRE IN BURNER, GROUND WIRE

C - Red with WHITE TRACE  
 IN OIL BURNER  
 D - White in Oil Burner

# Crack Pro®



ThorWorks Industries, Inc.  
Sandusky, Ohio  
(419) 626-4375

## BURNER REPLACEMENT PARTS

REF.#	ITEM	PART #	QTY
1	Motor	P662A012	1
2	Blower wheel	P662A013	1
3	Coupling	P662A016	1
4	Air guide	P662A022	1
9	Pump	P662A011	1
10	Tube assembly	P662A019	1
11	Oil valve	P662A020	1
14	Electrode kit	P662A018	1
15	Cad cell	P662A014	1
17	Igniter	P662A015	1
21	Igniter control board ( primary )	P662A010	1
NS	Nozzle (specify size)	P662A017	1
	Complete burner	P662A009	1

# MODEL **ADC** Oil Burner

## Instruction Manual

Type "F" air tube combinations

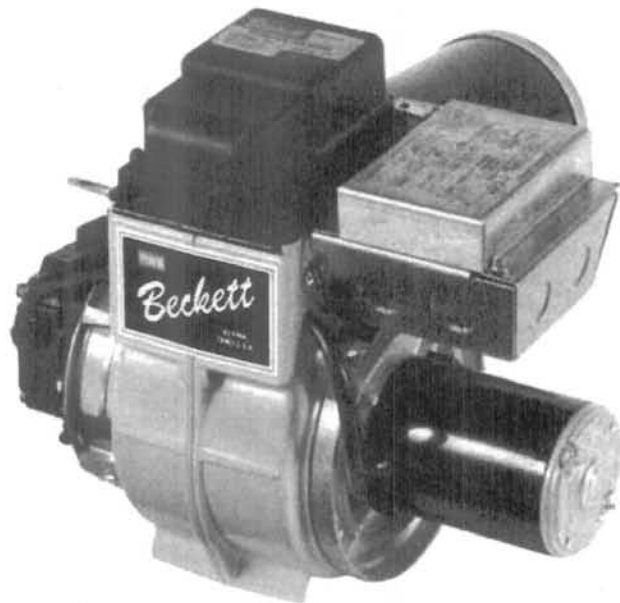

Thank you for purchasing a Beckett burner. With proper care and regular maintenance, it will provide years of trouble-free service. Please take a few minutes to read the section entitled 'To the Owner' inside this manual. Then, keep the manual in a safe place where it can be easily located if needed by your professional service technician.

*Beckett*

**Contents**

<b>1. Prepare before installing</b>	
A. Verify specifications .....	3
B. Be aware of hazard definitions.....	3
C. Notice special requirements .....	3
<b>2. General information</b>	
A. Equipment located in confined space .....	4
B. Exhaust fans and other air-using devices .....	4
C. Clearances to burner and equipment .....	4
D. Exhausting hazardous fumes .....	4
E. Low firing rate baffle .....	4
<b>3. Nozzle, Line, Electrode, &amp; Igniter Maintenance</b>	
A. Nozzle Assembly Maintenance.....	5
B. Replace Burner Nozzle .....	5
C. Check & Adjust Electrodes .....	6
D. Igniter Maintenance .....	6
E. Nozzle Line Assembly Maintenance.....	6
F. Check & Adjust 'Z' Dimension.....	6
<b>4. Fuel Supply Maintenance</b>	
A. Connect Fuel Lines.....	7
B. Fuel Supply Level or Above Burner .....	7
C. Fuel Supply Below Level of Burner.....	7
D. Fuel Line Replacement.....	7
E. Fuel Line Valve and Filter .....	7
<b>5. Burner Maintenance and Wiring</b>	
A. Burner installed on washer .....	7
B. Replacement Burner Installation.....	7
<b>6. Drive Component Maintenance</b>	
A. Motor, Blower Wheel, and Coupling Replacement .....	9
B. Pump Maintenance and Replacement.....	10
C. Valve Replacement .....	10
<b>7. Start up Burner and Set Combustion</b>	
A. Basic burner operation.....	11
B. Combustion set up.....	11
C. Set combustion with test instruments .....	11
<b>Appendix A. Maintain &amp; Service burner</b>	
A. Owner's information.....	12
B. Owner Service & Maintenance .....	12
C. Daily Maintenance .....	12
D. Weekly Maintenance .....	12
E. Regular Service/Maintenance.....	12
<b>Appendix B. Burner Troubleshooting</b>	
Troubleshooting Chart.....	13
<b>Appendix C. Replacement Parts</b>	
Burner Exploded View .....	15

### 1. Prepare before installing

#### A. Verify specifications

<b>Capacity</b>	"F" heads Firing rate ..... 0.75 – 2.50 GPH Input..... 105,000 – 350,000 Btu/h
<b>Fuels</b>	U. S. .... No. 1 or No. 2 diesel fuel, or kerosene – No.1 or No. 2 heating oil (ASTM D396)
<b>Electrical</b>	Power supply ..... 13.5 VDC Operating load ..... 15 Amps w/ igniter on, 8-10 Amps w/ igniter turned off Motor ..... 13.5 VDC, 1/6 hp, 3450 rpm, 10 Amps (max.), NEMA "M" flange, rotation CCW when facing shaft end Ignition Secondary ..... 20KVpk 30mA . Interrupted duty OR optional continuous duty
<b>Pump</b>	Outlet pressure ..... Note 1
<b>Air tube</b>	ATC code..... See Table 1
<b>Dimensions</b>	Height (maximum) ..... 11 ½ inches Width (maximum)..... 14 ³⁄₈ inches Depth (chassis only) ..... 6 ⁹⁄₁₆ inches Air tube diameter ..... 4 inches
<b>Temperature</b>	150° Max air temperature
Note 1. See equipment manufacturer's burner specifications for recommended outlet pressure. Pressure is 100 psig unless otherwise noted.	

Table 1– Air Tube Combination (ATC) codes\*

Firing rate (gph) (min-max)	Head	Static plate size (inches)	ATC codes for usable air tube lengths: ("A" in inches; see Figure 2)			
			4 ½	5	5 ¾	6 ¾
0.40-0.75	F0	3 ¾ U	AF44XR	-	AF53XR	AF65XR
0.75-1.25	F3	2 ¾	AF44XN	-	AF53XN	AF65XN
0.85-1.35	F4	2 ¾	AF44WH	-	AF53WH	AF65WH
0.85-1.65	F6	2 ¾	AF44YB	-	AF53YB	AF65YB
1.10-2.00	F12	2 ¾	AF44XO	-	AF53XO	AF65XO
1.65-2.50	F22	2 ¾	AF44XP	-	AF53XP	AF56XP

#### B. Be aware of hazard definitions

##### DANGER

Denotes presence of a hazard which, if ignored, will result in severe personal injury, death, or substantial property damage.

##### WARNING

Denotes presence of a hazard which, if ignored, could result in severe personal injury, death, or substantial property damage.

##### CAUTION

Denotes presence of a hazard which, if ignored, could result in minor personal injury or property damage.

##### NOTICE

Intended to bring special attention to information, but not related to personal injury or property damage.

#### C. Notice special requirements

##### DANGER

- This equipment must be installed, adjusted and started only by a **qualified service agency** – an individual or agency, licensed and experienced with all codes and ordinances, who is responsible for the installation and adjustment of the equipment. **All oil burners should be installed in accordance with regulations of the latest revision of the National Fire Protection Association Standard NFPA 31 and in complete accordance with all local codes and authorities having jurisdiction. Regulation of these authorities take precedence over the general instructions provided in this installation manual. Note that this burner is NOT recommended for Residential use.**

- For recommended installation practice in Canada, refer to the latest version of CSA Standard B139.

##### WARNING

**Read all instructions before proceeding.** Follow all instructions completely. Failure to follow these instructions could result in equipment malfunction, causing severe personal injury, death or substantial property damage.

##### NOTICE

**Concealed damage** — If you discover damage to the burner or controls during unpacking, notify the carrier at once and file the appropriate claim.

##### NOTICE

When contacting Beckett for **service information** — Please record the **burner serial number** (and have available when calling or writing). You will find the serial number on the silver label located on the left rear of the burner. See illustration below.

Figure 1 – Typical Burner Nameplates

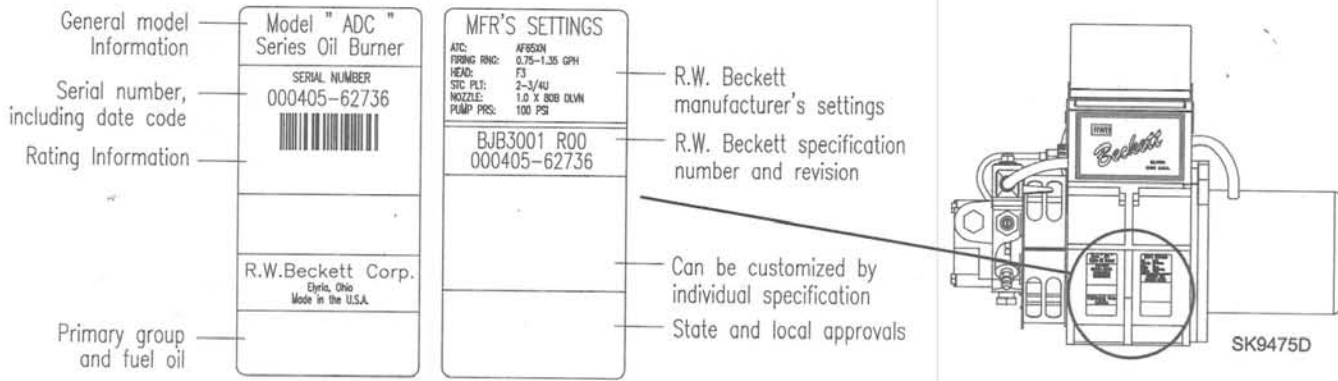

## 2. General information

Your burner was designed, installed and adjusted at the factory prior to shipment and should not require additional adjustments. Refer to the Troubleshooting section of this manual when experiencing a possible fault condition.

**DANGER**

The Model ADC Burner requires a continuous supply of 11 to 16 volts DC at 15 amperes measured at the burner during operation. An automotive or a small engine charging system that is capable of supplying the required continuous voltage/ampereage is recommended with certain road equipment, such as asphalt hot patchers and similar applications. This is especially true while maintaining nominal load temperatures during idle periods. A low or erratic power supply could result in impaired burner operation, severe delayed ignition or an explosion inside the heat exchanger resulting in a burn and/or asphyxiation hazard.

**WARNING**

If the burner is not supplied with a reliable combustion air source, the burner cannot properly burn the fuel. This would result in incomplete combustion, causing sooting and probable emission of carbon monoxide. Severe personal injury, death or substantial property damage could occur.

Burner head type	Low Firing Rate Baffle, if specified:
F0 <sup>1</sup>	up to 0.65 gph
F3	up to 0.85 gph
F4 or F6	up to 0.90 gph

### A. Equipment located in confined space

The confined space should have two (2) permanent openings: one near the top of the enclosure and one near the bottom of the enclosure. Each opening shall have a free area of not less than (1) one square inch per 1,000 BTU's per hour of the total input rating of all equipment within the enclosure. The openings shall have free access to the building interior, which should have adequate infiltration from the outside.

### B. Exhaust fans and other air-using devices

(Typically not used)

Size air openings large enough to allow for all air-using devices in addition to the minimum area required for combustion air. If there is any possibility of the equipment room developing negative pressure (because of exhaust fans, for example), either pipe combustion air directly to the burner or provide a sealed enclosure for the burner and supply it with its own combustion air supply.

### C. Clearances to burner and equipment

- Provide space around burner and equipment for easy service and maintenance.
- Check minimum clearances against those shown by the equipment manufacturer and by applicable codes.

### D. Exhausting Hazardous Fumes

An asphyxiation hazard could exist due to improper combustion levels that impair proper burner operation. Copious amounts of smoke and carbon monoxide could be produced in a confined area. Also, be conscious of any fumes produced by the materials that are being heated. Always ensure adequate ventilation to exhaust all fumes.

### E. Low Firing Rate Baffle

The Low Firing Rate Baffle (LFRB) (see Replacement Parts) reduces the air flow and pressure. The LFRB is sometimes used for firing rates under 1.00 GPH as listed in the table below. Refer to the equipment manufacturer's instructions. Do not omit the LFRB when specified. Omitting the baffle when specified or installing the baffle when not specified could result in poor burner performance.

### 3. Nozzle, Nozzle Line, & Electrode Maintenance

#### A. Nozzle Maintenance

Refer to the following figure for nozzle, nozzle line and electrode familiarization.

Figure 2 – Nozzle, line & electrode assembly

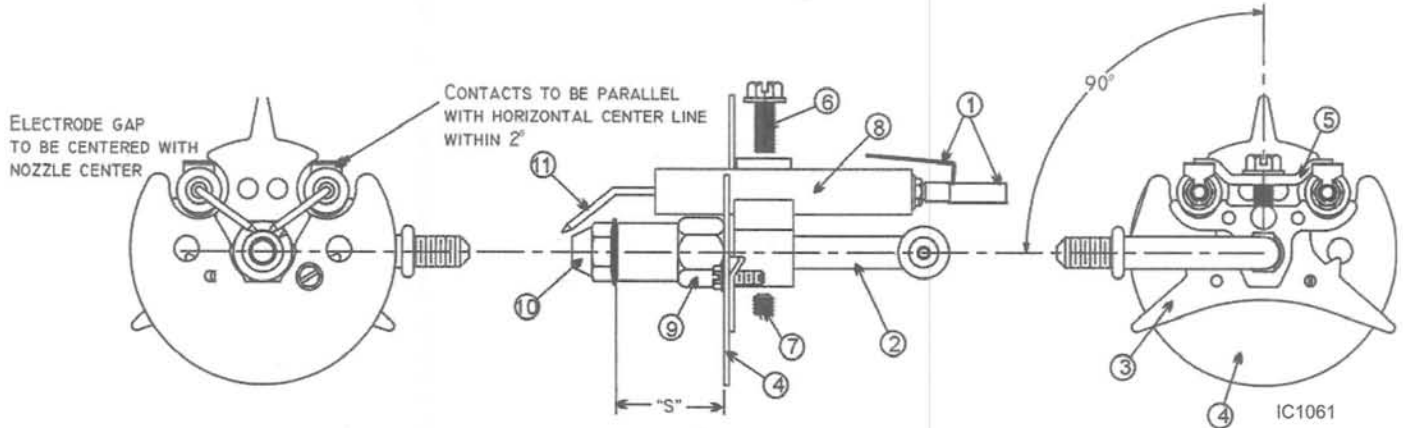

Item #	Description
1	Electrode Contact (3" ATC or Extension over 3")
2	Nozzle Line
3	Spider Spacer Assembly
4	Static Plate
5	Electrode Clamp
6	Electrode Clamp Retaining Screws
7	Nozzle Line Setscrew
8	Electrode Insulator
9	Nozzle Adapter
10	Nozzle Tip
11	Electrode Tip

Figure 3 – Electrode Tip Settings

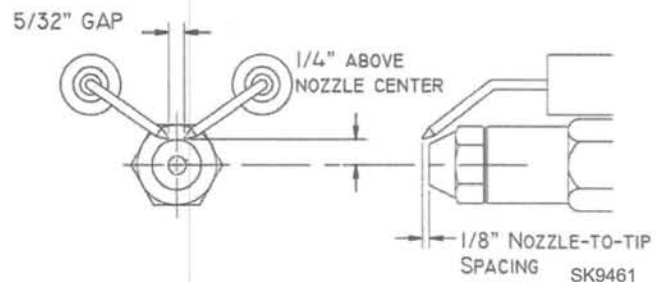

#### B. Replace burner nozzle

##### WARNING

Make certain the correct nozzle is selected for the actual pump pressure. Nozzles are rated for 100 psig operation. For applications with pump pressure above 100 psig, the nozzle rated capacity will be lower than the equipment firing rate. Use only the specified spray pattern. Failure to use the correct nozzle size and type can result in unacceptable combustion, possibly causing severe personal injury, death or substantial property damage.

1. If applicable, remove the plastic plug protecting the nozzle adapter threads.
2. Place a 3/4" open-end wrench on the nozzle adapter. Insert the nozzle into the adapter and finger tighten. Finish tightening with a 5/8" open-end wrench.
3. If the nozzle is already installed, remove the nozzle line assembly to verify that the nozzle size and spray pattern are correct for the application (per equipment manufacturer's information). Verify that the electrode tip settings comply with Figure 3.

##### CAUTION

Use care when removing and installing oil nozzles:

- Inspect the nozzle adapter prior to installing the nozzle. If the sealing surface is grooved or scratched, replace the nozzle line assembly. If a damaged nozzle adapter is not replaced, oil could leak at the nozzle-adapter joint, causing serious combustion problems.
- Protect the nozzle orifice and strainer when installing a nozzle. If there is dirt in the orifice or it is scratched or damaged, the nozzle will not function properly.
- Do not over-torque the nozzle when installing. This will cause deep grooves in the nozzle adapter, preventing a seal when a new nozzle is installed.
- Use a wrench that secures the adapter or use 3/4" and 5/8" open-end wrenches. DO NOT attempt to remove or install a nozzle without securing the adapter. The nozzle alignment could be seriously damaged.
- Do not squeeze the electrodes too tightly when handling the nozzle line assembly. This could change the electrode tip settings or damage the ceramic electrode insulators.

## Instruction Manual – Model ADC Oil Burner

- Carefully check and realign electrode tips after replacing the nozzle, ensuring the electrode settings comply with Figure 3.

### C. Check/adjust electrodes

Check the electrode tip settings. Adjust if necessary to comply with the dimensions shown in Figure 3. To adjust, loosen the electrode clamp screw and slide/rotate electrodes as necessary. Securely tighten the clamp screw when finished.

### D. Igniter Maintenance

The igniter assembly does not require any adjustments beyond making sure the springs and the burner electrode rods make solid contact when the igniter is in the closed position. The sealing surfaces of the gaskets should be checked and replaced at the first signs of any damage or deterioration. Clean any dirt or residue from the porcelain bushings, springs, and baseplate.

The simplest way to check igniter operation is by supplying voltage to the input and checking to see whether an arc is produced. Check by either looking or listening to see if there is an arc across the electrodes while the burner is running and the igniter is energized.

The igniter must be grounded to the burner before checking the following. To check the igniter, insure that the burner is off, and use an ohmmeter to check the resistance between one of the springs and exposed metal on the burner (for example, a housing bolt). The meter should read less than 2000 ohms when measuring the spring-to-ground resistance at either spring.

The igniter should be replaced if the meter indicates an open circuit, the difference between the two spring-to-ground resistance readings is greater than 20%, or the spring-to-spring resistance does not read approximately twice the spring-to-ground reading.

Figure 4 – Igniter hinge and retainer clips

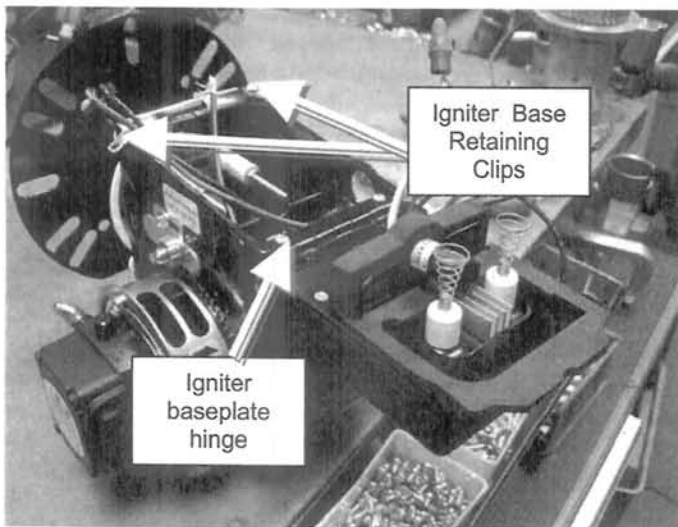

### E. Servicing nozzle line assembly

Before proceeding, turn off power to the burner.

- Disconnect the oil connector tube from the nozzle line.
- Referring to Figure 4, loosen the two screws securing the igniter retaining clips and rotate both clips to release the igniter baseplate. Then tilt the igniter back on its hinge.
- Remove the splined nut.
- Remove the nozzle line assembly from the burner, being careful not to damage the electrodes or insulators while handling. To ease removal of long assemblies (over 9 inches), rotate the assembly 180° from the installed position after pulling partially out of the tube.
- To replace the nozzle line assembly, reverse the above steps.

### F. Check/adjust "Z" dimension

Refer to Figure 5. The critical "Z" dimension is the distance from the face of the nozzle to the flat face of the head. This distance for **F heads** is  $1 \frac{1}{8}$ ". The "Z" dimension is factory set for burners shipped with the air tube installed but should always be verified during service and installation. If the "Z" dimension is out of adjustment, perform the following steps.

Before proceeding, turn off power to the burner.

- Disconnect the oil connector tube from the nozzle line.
- Referring to Figure 3, loosen the splined nut from the nozzle line. Loosen the hex head screw securing the escutcheon plate to the burner housing.
- A Beckett T650 gauge should be used to set the Z-dimension. Place the end of a ruler at the face of the nozzle and, using a straight edge across the head, measure the distance to the face of the head.
- Slide the nozzle line forward or back until this dimension for **F heads** is  $1 \frac{1}{8}$ ".
- Tighten the hex head screw to secure the escutcheon plate to the burner chassis. Then tighten the splined nut and attach the oil connector tube.
- Recheck the "Z" dimension periodically when servicing to ensure the escutcheon plate has not shifted. You will need to reset the "Z" dimension if you replace the air tube or nozzle line assembly.

#### NOTICE

The Beckett **Z gauge** (part number Z-2000) is available to permit checking the **F head** "Z" dimension without removing the burner.

Figure 5 – Z- Dimensions using gauge

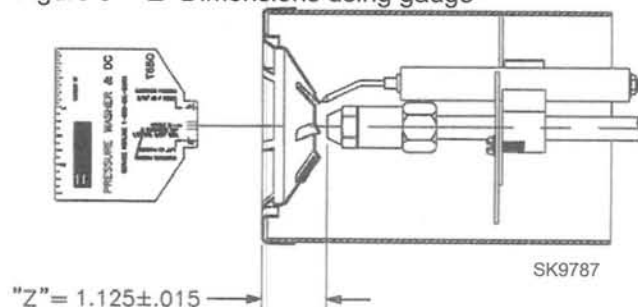

### 4. Fuel Supply Maintenance

#### A. Connect fuel lines

For oil supply system specifications for tanks not mounted on machines, carefully follow the pump manufacturer's literature and the latest edition of NFPA 31. If this information is unavailable, use the following basic guidelines:

**NOTICE**

Pumps with automatic bypass do not require a bypass plug.

**WARNING**

The burner pump is shipped without the bypass plug installed. You must install this plug on two-pipe oil systems. If the unit is a one-pipe oil system DO NOT install the plug in the pump. Failure to comply could cause pump seal failure, oil leakage and the potential for a fire and injury hazard.

#### B. Fuel supply level with or above burner

The burner may be equipped with a single-stage pump. If a one pipe system is installed, insure that a bypass plug is not installed in the pump, then connect the fuel supply to the burner with a single supply line. Note that manual bleeding of the pump is required on initial start-up. When connecting a two-pipe fuel supply, install the pump bypass plug.

**WARNING**

The oil supply inlet pressure to the pump cannot exceed 3 psi. Install a pressure-limiting device in accordance with NFPA 31.

#### C. Fuel supply below level of burner

When the fuel supply is located below the level of the burner, a two-pipe fuel supply system is not necessary, but depending on the fuel line diameter and horizontal and vertical length, the installation may also require a two-stage pump. Consult the pump manufacturer's literature for lift and vacuum capability.

#### D. Fuel line replacement (remote tank only)

When replacing fuel lines, continuous lengths of heavy wall copper tubing is recommended. To ensure a tight seal, always use flare fittings. Never use compression fittings.

Always install fittings in an accessible location. To avoid vibration noise, fuel lines should not run against the appliance or the ceiling joists.

**WARNING**

Never use Teflon tape on any fuel fitting. Tape fragments can lodge in fuel line components and the fuel pump, damaging the pump and preventing proper operation.

#### E. Fuel line valve and filter

Shutoff valves should be located in the oil supply line, never the return line.

### 5. Burner Maintenance & Wiring

#### A. Burner Installed on Washer

Refer to appliance manufacturer's wiring diagram for electrical connections. Refer to Appendix A for burner maintenance procedures.

#### B. Burner Replacement

Burner wiring may vary, depending on the actual primary control and furnished options. Refer to Figure 6 for typical burner wiring, showing CAD cell primary controls. Note that the relay and control, shown in the wiring diagram are optional features.

All wiring must be in accordance with the latest revision of National Electric Code NFPA 70 and all local codes and regulations.

**NOTICE**

The wiring diagrams in this manual are for general reference only. Refer to the equipment manufacturer's literature or the diagrams supplied with the equipment. Failure to install correct wiring could result in severe personal injury, death or substantial property damage.

**WARNING**

Electrical shock hazard. Disconnect power before servicing.

Figure 6A – Recommended Field Wiring

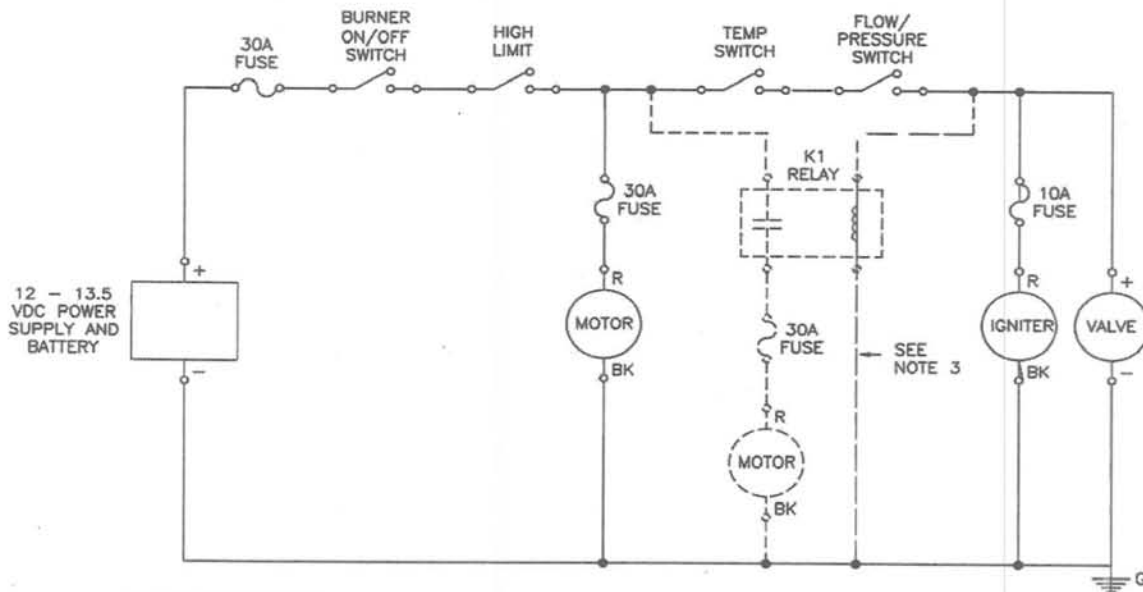

- NOTES:
1. All wires are to be 14 GA. Minimum (18 GA. for valve & igniter) to prevent voltage drop between battery and burner.
  2. Motor runs continuously in normal configuration.
  3. Optional motor configuration shown in dashed lines cycles motor with trigger. K1 relay to be S.P.S.T. N.O. contacts with 25 A minimum current rating. (100 amp in-rush) @ 12 volts DC.

SK9789

Figure 6B – Wiring with ICB

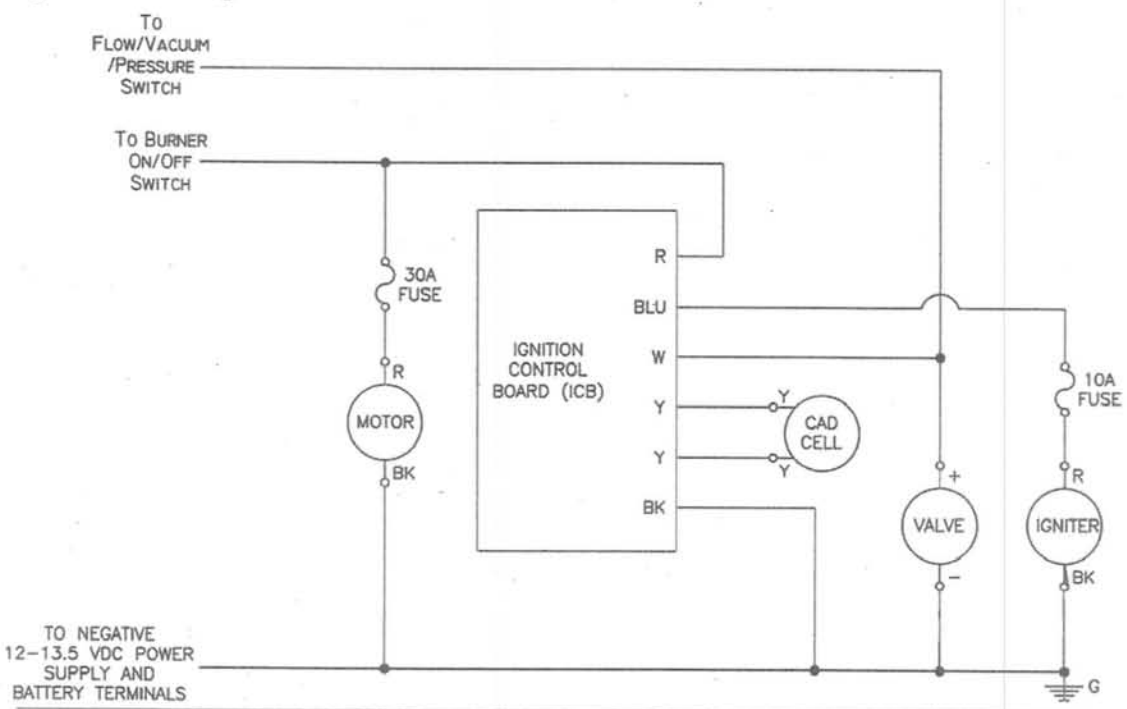

- NOTES:
1. All wires are to be 14 GA. Minimum (18 GA. for valve & igniter) to prevent voltage drop between battery and burner.
  2. Alternate wiring: white wire of 1CB may be wired to red wire of 1CB, and positive valve wire may be wired to flow or pressure switch.
  3. Hard-wire burner ground to battery. DO NOT USE CHASSIS GROUND SYSTEM.

SK9790

Figure 6C – Wiring with 7434 Control

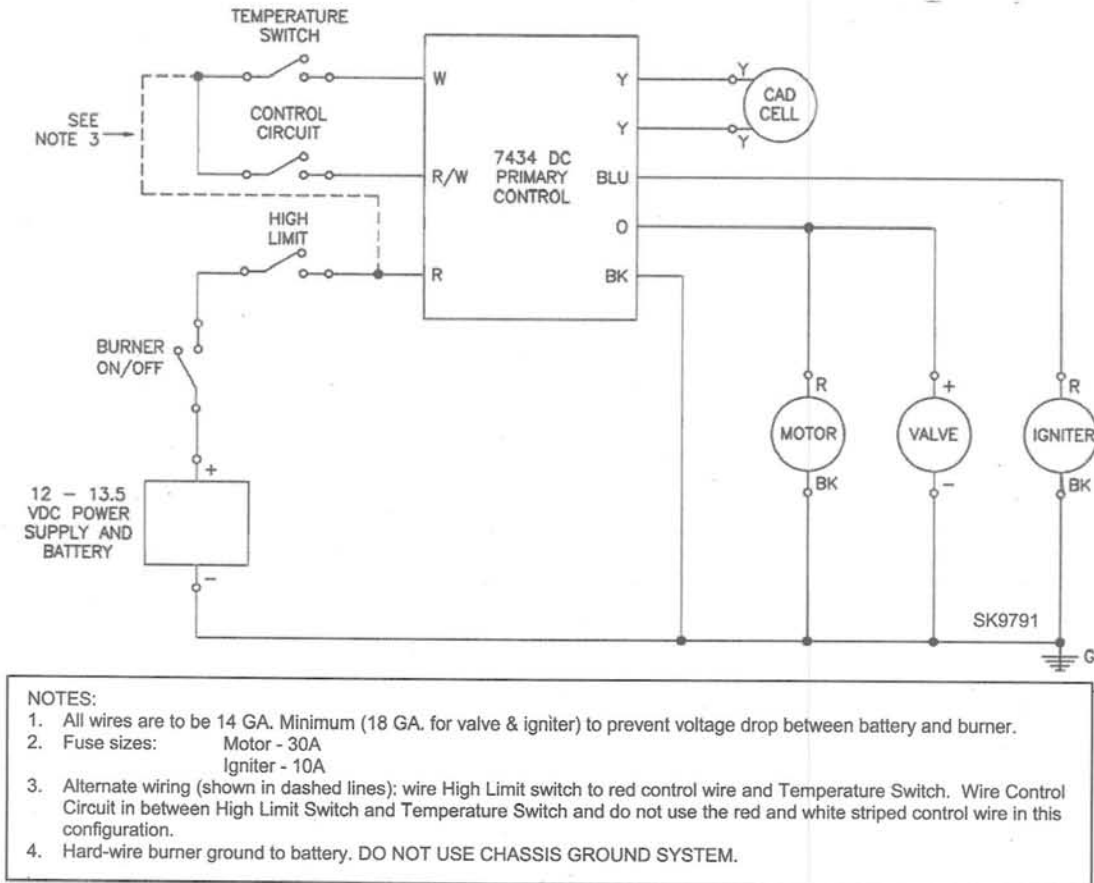

## 6. Drive component maintenance

### A. Motor, blower wheel, and coupling replacement

The motor will require replacement if the proper voltage is measured at the motor input, and the motor will either not run, or the current draw with a free running pump exceeds 10% of the rated current.

To replace the burner motor, coupling and/or blower wheel perform the following steps.

1. Before servicing, turn off and/or disconnect all power to the burner.
2. Disconnect the burner motor wires.
3. Remove the bolts securing the motor to the burner housing.
4. Remove the motor, coupling, and blower wheel.
5. Loosen the set screw on the blower wheel to slide the existing wheel off the shaft.
6. Slide the new blower wheel onto the old shaft (after thoroughly cleaning housing) and/or slide the old blower wheel onto the new motor shaft.
7. Place a .030" ( $1/32" \pm 1/64"$ ) feeler gauge between the blower wheel and the motor housing.
8. Slide the blower wheel toward the motor until it contacts the feeler gauge.
9. Rotate the blower wheel until the setscrew is centered on the flat of the motor shaft. Tighten the setscrew to secure the wheel.

Figure 7. – Blower Wheel

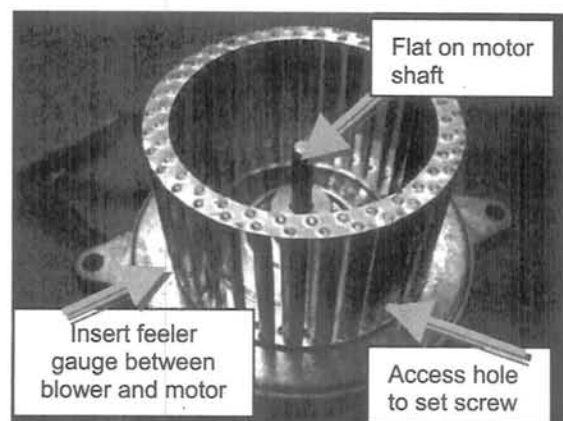

10. Slide the motor coupling on the motor shaft then install the motor on the burner housing. Insure that the motor coupling fits between the motor shaft and the pump shaft inside the housing. Tighten the motor retaining screws. Reconnect the wires.
11. Restore power, start the burner and perform the combustion test described previously in this manual.

## Instruction Manual – Model ADC Oil Burner

### B. Pump Maintenance

#### CAUTION

This Equipment must be installed, adjusted and started only by a qualified service technician. – an individual or agency, licensed and experienced with all codes and ordinances, who is responsible for the installation and adjustment of the equipment. The installation must comply with all local codes and ordinances and with the National Fire Protection Association Standard for Liquid Fuel Equipment, NFPA 31 (or CSA B139).

#### General pump information

Important information - Long or oversized inlet lines may require the pump to operate dry during initial bleeding period. In such cases, the priming may be assisted by injecting fuel oil in the pump gear set. Under lift conditions, lines and fittings must be air tight. To assure this, "Pipe Dope" may be applied to both the used and unused inlet and return fittings.

#### CAUTION

Do NOT use Teflon tape! Do NOT use compression fittings!

Mounting Position - Beckett CleanCut pump may be mounted in any position (except upside-down during single pipe installation).

Vacuum check - A Vacuum Gage may be installed in either of the 1/4" NPT inlet ports.

Pressure check- When a pressure check is made use the nozzle port. If the bleed port is used, the reading on the gauge should be approximately 5 psig higher than the pressure reading on the nozzle port.

Cutoff check - To check cutoff pressure dead head a pressure gage in the nozzle port. Run the burner for a short period of time. Shut the burner off. The pressure will drop and hold above zero.

#### CAUTION

Pressurized or gravity feed installations must not exceed 3 psi on inlet line or return line at the pump per NFPA 31. A pressure greater than 10 psi may cause damage to the shaft seal.

#### Mounting the pump

To install a CleanCut pump on a pre 2002 burner chassis with an existing shutter tab follow the instructions included with the pump.

### C. Valve Coil and Stem Replacement

To determine if the valve coil requires replacement perform the following steps.

1. Remove the cord set from the valve.
2. Place the leads from an ohmmeter across the coil.

3. A 12 volt coil should measure between 15 and 25 ohms.
4. If the meter indicates an open circuit, replace the coil.

Figure 8. – Pump and Valve assemblies

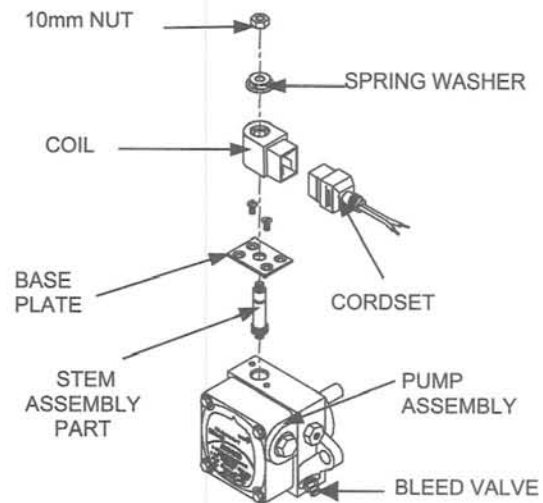

To check pump operation perform the following.

1. Check the operating pressure by removing the copper tubing from the nozzle line and installing a pressure gauge in the line. With the motor running and the coil energized, check the gauge. The pressure should read 100 psig unless otherwise stated.
2. To check the cutoff function, deadhead the pressure gauge onto the copper connector tube attached to the nozzle port. Run the burner for a short period of time. Shut the burner off; the pressure should drop and hold.

To replace the coil and/or valve stem assembly perform the following steps.

1. Before servicing, turn off and/or disconnect all power to the burner.
2. Use the shut-off valve between the fuel tank and the pump to block oil from the burner.
3. Remove the copper Tube Assembly when replacing the pump or when removing the coil and the tube blocks the coil.
4. Using a flat tip screwdriver, press the flat tip into the spring washer to prevent it from rotating.
5. Using a 10mm wrench or adjustable wrench, remove the nut and spring washer.
6. Remove the coil by lifting it straight up.
7. Remove the two base plate screws, then the base plate by lifting straight up.
8. Remove valve stem assembly by pulling straight up.
9. To install the new stem and coil assemblies, follow the above steps in reverse order, tightening each part as you go.
10. Restore power, start the burner and perform the combustion test described previously in this manual.

## 7. Start up burner & Set combustion

### A. Basic burner operation

On the Beckett ADC Oil burner standard configuration, the motor and igniter operate continuously while the valve, that controls oil flow, is cycled by the switches on the power washer. The **motor** is used to drive the blower and pump. The rotational speed of the motor is determined by the voltage supplied and the load placed on the motor. Pump pressure and air settings are the main factors affecting the motor load. The **igniter** converts battery DC voltage into a high voltage spark to ignite the oil. The igniter is capable of running continuously as long as the blower wheel is circulating air across the igniter base. The **pump** and **solenoid valve** are used to control the flow of oil from the reservoir to the nozzle. The pump pressurizes the oil. When energized, the valve enables high pressure oil flow to the nozzle. An **optional control circuit** can also be supplied to reduce current draw on the charging system by turning the igniter off after a flame has been established. This option controls igniter operation based on a signal from a light sensing CAD cell. When light hits the cell the control will sense a decrease in resistance across the sensor. A few seconds delay will occur prior to the igniter switching off. As long as sufficient light is reaching the cell eye, the igniter will remain off. If light is removed from the sensor, the igniter will turn on until light is again sensed by the CAD cell.

Variations to the burner circuits may occur due to optional temperature, pressure, and vacuum switches that control burner operation. Note that when external switches are used to control the motor operation they must be sized correctly for the rated current or a relay should be installed to isolate the switches from the motor's full load current.

### B. Combustion set-up

#### WARNING

Do not attempt to start the burner if excess fuel or vapor has accumulated in the equipment. Starting the burner under these conditions could result in a puffback of hot combustion gases, high smoke levels, or hazardous operation.

Open all shutoff valves located in the oil supply line to the burner.

As soon as burner motor starts rotating **bleed all the air from the pump**. (Required with single-pipe systems)

To bleed the pump, attach a clear plastic hose over the vent fitting. Loosen the fitting and catch the oil in an empty container. Tighten the fitting when all air has been purged from the supply system. **Note:** If the burner stops after a flame is established, the unit probably requires additional bleeding. Continue to bleed the system until the pump is primed and a flame is established when the vent fitting is closed.

### C. Set combustion with instruments

#### WARNING

The combustion level should be adjusted using dedicated combustion test equipment. Failure to properly set the burner could result in inefficient operation, and/or conditions that could potentially cause severe personal injury, death or substantial property damage.

#### NOTICE

Combustion testing instruments can be purchased from most HVAC suppliers. If your usage does not warrant purchasing the equipment, contact a reputable HVAC contractor to perform a combustion test and adjustment.

1. Allow the burner to run for approximately 5 to 10 minutes.

Figure 9. – Air supply components

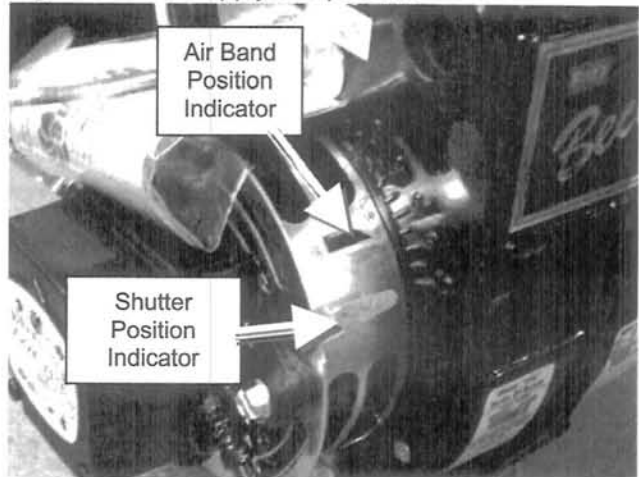

2. Follow these three steps to properly adjust the burner:
  - Step 1: Use a smoke tester to check for a clean flame. If necessary, adjust the air shutter and air band to obtain a trace to one smoke. See Figure 2.
  - Step 2: With the smoke level at a trace to one, measure the CO<sub>2</sub> (or O<sub>2</sub>). This will be the reference point for further adjustments.
  - Step 3: Increase the air to reduce smoke levels to zero or a trace. Recheck the CO<sub>2</sub> (or O<sub>2</sub>), it should be lower than the initial reading.
3. Once the combustion level is set, tighten the fasteners on the air band and air shutter.
4. Start and stop the burner several times to ensure satisfactory operation.
5. Test the equipment safety controls to verify that they function according to the manufacturer's specifications.

## Appendix A. Maintain & Service Burner

### A. Owner's information

#### WARNING

Have your equipment inspected at regular intervals by a qualified service agency to assure continued proper operation. The burner should be adjusted using dedicated combustion test equipment. Failure to properly set the burner could result in inefficient operation, and/or conditions that could potentially cause severe personal injury, death or substantial property damage.

The following could result in fire hazard, severe personal injury, death or substantial property damage. Read carefully.

- Never attempt to use gasoline in your burner.
- Never store gasoline or combustible materials near the burner.
- Never attempt to light the burner by throwing burning material into the fire chamber.
- Never attempt to use crankcase or waste oil or material other than the approved fuel oils in this burner.
- Never restrict the air inlet openings to the burner or the combustion air ventilation openings in the room.

### B. Owner service and maintenance

Properly installed and maintained, your ADC burner will provide years of efficient, trouble-free operation. Please take care of your equipment by following the warnings provided and by doing the following (notify your qualified service agency if your burner is not operating properly):

#### WARNING

This equipment should be serviced only by a qualified service agency. The appropriate test instruments must be used. Failure to do so could result in burner or equipment failure, could potentially cause severe personal injury, death or substantial property damage.

### C. Daily

Check the area around your burner/equipment to make sure:

- air ventilation openings are clean and unobstructed
- nothing is blocking the burner inlet air openings
- no combustible materials are stored near the equipment
- there are no signs of oil or water leakage around the burner or equipment

### D. Extended down time

If the equipment will be stored for an extended period of time, insure that the fuel tank is full and add a fuel stabilizer to the tank.

### E. Regular Service/Maintenance

Have your burner, power washer, crack sealer, etc. serviced annually by your qualified service agency.

The following components/assemblies should be checked/adjusted/replaced on a regular basis. Refer to the Replacement Parts exploded view for part locations.

- ❑ Replace the oil supply line filter if applicable. The line filter cartridge must be replaced to avoid contamination of the pump and nozzle.
- ❑ Inspect the oil supply system. All fittings should be leak-tight. The supply lines should be free of water, sludge and other restrictions.
- ❑ Remove and clean the pump strainer.
- ❑ Replace the nozzle with one having the same specifications from the same manufacturer.
- ❑ Clean and inspect the electrodes for damage, replacing any that are cracked or chipped.
- ❑ Check electrode tip settings. Replace electrodes if tips are rounded.
- ❑ Inspect the igniter spring contacts. Clean or replace if corroded.
- ❑ Clean the cad cell, if applicable.
- ❑ Make sure Low Firing Rate Baffle is in place if required for the burner application. Omitting the baffle can result in unacceptable burner combustion.
- ❑ Inspect all gaskets including the igniter base plate gasket. Replace any that are damaged or missing.
- ❑ Clean the blower wheel, air inlet, air guide, retention head and static plate of any dirt, asphalt or other material.
- ❑ Check motor current. The amp draw should not exceed the nameplate rating by more than 10%.
- ❑ Check all wiring for loose connections or damaged insulation.
- ❑ Check the pump pressure and cutoff function.
- ❑ Check primary control safety lockout timing if applicable. Refer to the information supplied by the control manufacturer for procedures.
- ❑ Check ignition system for proper operation.
- ❑ Inspect the exhaust system for soot accumulation or other restriction.
- ❑ Clean the equipment thoroughly according to the manufacturer's recommendations.
- ❑ Check the burner performance. Refer to Section 3.
- ❑ It is good practice to make a record of the service performed and the combustion test results.

### Appendix B. Burner Troubleshooting

Oil burners that are designed for use in pressure washers are built to take temperature extremes vibration and rough handling. When performing the following troubleshooting steps, we assume that the oil burner motor and ignition transformer operate continuously and the oil solenoid valve, which controls oil flow, is cycled by the trigger on the wand. We also assume that there is power to the burner, and fuel in the tank.

In addition to normal mechanic's tools, it is recommended to have the following equipment on hand. An electrical meter capable of measuring volts, ohms, and amps, an ignition transformer tester, a smoke pump tester, combustion analyzer and a zero to 200 psi oil pressure gauge.

#### Troubleshooting Chart

Symptom	Possible cause	Additional info/Procedure
<b>Oil not igniting</b>	<p>If the burner is not igniting, the burner motor, drive coupling, and oil pump are operating and oil is flowing to the nozzle through the solenoid valve, check the following possibilities.</p> <ol style="list-style-type: none"> <li>1) Check the air shutter adjustment. If the air shutter is opened too far, the flow of air may prevent the igniter from reaching the oil spray. This may appear as a white vapor exhaust from the coil.</li> <li>2) The ignition system may have failed to supply an adequate arc to ignite the oil. Check the battery and charging system to insure a continuous supply of 11 to 16 volts DC (15 amps)</li> <li>3) Check the electrodes for wear and damage. Insure that the electrodes are adjusted properly.</li> </ol>	<ol style="list-style-type: none"> <li>1) Refer to Section 7, C.</li> <li>2) Refer to Section 2.</li> <li>3) Refer to Section 3, C.</li> </ol>
<b>No Flame</b>	<p>If there is no flame, the burner motor and ignition transformer operate continuously and the oil solenoid valve, which controls oil flow, is cycled by the trigger in the wand, check the following possibilities.</p> <ol style="list-style-type: none"> <li>1) Check for a plugged oil nozzle.</li> <li>2) If the coil on the solenoid valve is actuating, insure that the valve is opening.</li> <li>3) Check for sufficient fuel pressure. Pressure is 100psig unless otherwise noted.</li> <li>4) Check the pump pressure. Check for air in fuel lines.</li> <li>5) Check burner for broken motor coupling. If the coupling is broken check pump rotation prior to replacing the coupling.</li> <li>6) Check for contaminated fuel and/or partially plugged fuel filter.</li> </ol>	<ol style="list-style-type: none"> <li>1) Refer to Section 3, A.</li> <li>2) Refer to Section 6, C.</li> <li>3) Refer to Section 6, B.</li> <li>4) Refer to Section 6, B.</li> <li>5) Refer to Section 6, A.</li> <li>6) Refer to Section 4, E.</li> </ol>
<b>Motor not operating</b>	<p>If the blower motor is not operating, check the following possibilities.</p> <ol style="list-style-type: none"> <li>1) Check voltage at the motor to insure that switches and relays, in line with the motor, are operating properly.</li> <li>2) Check pump and motor shaft operation. They should work freely without binding.</li> <li>3) Check the fuse and/or breaker on the motor.</li> </ol>	<ol style="list-style-type: none"> <li>1) Refer to Section 2.</li> <li>2) Refer to Section 6, B.</li> <li>3) Refer to Section 6.</li> </ol>
<b>No oil spray</b>	<p>If the blower motor is operating, there is fuel in the reservoir, but oil does not spray out the end of the nozzle, check the following possibilities.</p> <ol style="list-style-type: none"> <li>1) Check for a broken or stripped coupling between the pump and the motor.</li> <li>2) Check the pump output for oil.</li> <li>3) Check operation of the oil valve.</li> <li>4) Check for a plugged nozzle</li> <li>5) Check for air in the oil line</li> <li>6) Check for fuel contamination or plugged filter</li> </ol>	<ol style="list-style-type: none"> <li>1) Refer to Section 6, A.</li> <li>2) Refer to Section 6, B.</li> <li>3) Refer to Section 6, B.</li> <li>4) Refer to Section 3, A.</li> </ol>

## Instruction Manual – Model ADC Oil Burner

<b>Fluctuating or no pump pressure</b>	If the pump pressure, as determined by a pressure gauge, is erratic or does not exist, check the following possibilities. <ol style="list-style-type: none"><li>1) Check motor rotational speed. Low rpm's can cause erratic or no pump pressure.</li><li>2) Check for a broken or worn motor coupling</li><li>3) Check that the pump turns freely</li><li>4) Check for air leaks in the lines</li><li>5) Check for oil froth within the reservoir</li><li>6) Check voltage at the motor</li><li>7) Check for fuel contamination or partially plugged filter</li></ol>	<ol style="list-style-type: none"><li>1) Refer to Section 6, A.</li><li>2) Refer to Section 6, B.</li><li>3) Refer to Section 6, B.</li> <li>4) Refer to voltage rating on Nameplate.</li></ol>
<b>Slow motor rotation</b>	If the blower motor is not operating at the rpm's listed on the nameplate, check the following. <ol style="list-style-type: none"><li>1) Check the supply voltage to the motor.</li><li>2) Check for free operation of the motor shaft and pump assembly.</li></ol>	<ol style="list-style-type: none"><li>1) Refer to voltage rating on Nameplate.</li><li>2) Refer to Section 6, A &amp; B.</li></ol>

### Appendix C. Replacement Parts

For best performance specify genuine **Beckett** replacement parts

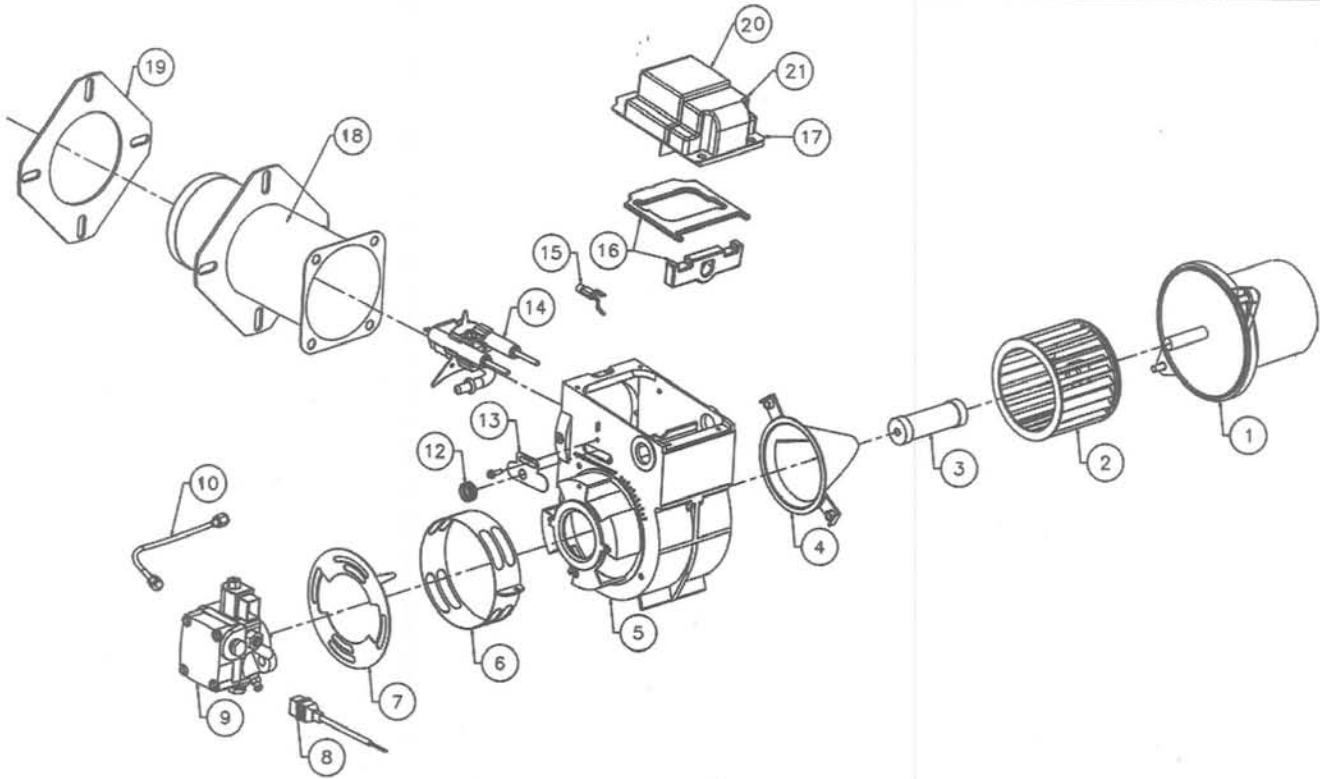

Illustration #	Description	Part#
1	DC Motor	21699UF
2	Blower Wheel	2140401
3	Coupling	21405
4	Air Guide	31231U
5	Burner Housing - Black- Gray-	5874BKU 5877
6	Air Band	5151501
7	Air Shutter 4 Slot Air Shutter 8 Slot	3709 3494
8	Cord set	21807
9	Pump (CleanCut)	218440ZU
10	Tube assembly	21877U

Illustration #	Description	Part#
11	12 volt Coil	21754U
12	Escutcheon plate spline nut	3666
13	Escutcheon plate	3493
14	Electrode kit	5700
15	Cad cell detector	7492/7006
16	Igniter gasket kit	51411
17	Igniter w/ICB Igniter w/o ICB	51776U 51777U
18	Air tube assemblies	Specify
19	Flange mounting gasket	
20	Ignitor only	7435U
21	Ignitor Control Board	51663

# Limited WARRANTY

For Residential, Commercial and Specialty Burners

The R. W. BECKETT CORPORATION ("Beckett") warrants to persons who purchase its Beckett burners from Beckett for resale or for incorporation into a product for resale ("Customers") that its equipment is free from defects in material and workmanship under normal use and service for 60 months from the date of manufacture for Residential Burners and 18 months from the date of manufacture for Commercial and Specialty Burners. *Residential burner models include:* AF, AFG, AFII, NX, SF, SR and SMG. *Commercial burner models include:* CF375, CF500, CF800, CF1400, CF2300A, CF2500, CF3500A, CG10, CG15, CG25 and CG50. *Specialty burner models include:* ADC, ADCP, ARV, SDC and SM. The provisions of this warranty are extended to individual major burner components as follows:

- a) 60 months from date of manufacture for all Beckett-branded major components, except for 12 Vdc components.
- b) 18 months from date of manufacture for all non-Beckett-branded major components and Beckett branded 12 Vdc components.

Note: Normal service items found to be defective upon receipt by the customer are covered by this warranty.

**THIS WARRANTY DOES NOT EXTEND TO EQUIPMENT SUBJECTED TO MISUSE, NEGLIGENCE, OR ACCIDENT; NOR DOES THIS WARRANTY APPLY UNLESS THE PRODUCT COVERED BY IT IS PROPERLY INSTALLED BY A QUALIFIED, COMPETENT TECHNICIAN, WHO IS LICENSED WHERE STATE AND LOCAL CODES REQUIRE, AND WHO IS EXPERIENCED IN MAKING SUCH INSTALLATIONS, IN ACCORDANCE WITH THE LATEST EDITION OF NFPA NO. 31 OF THE NATIONAL FIRE PROTECTION ASSOCIATION, THE LATEST EDITION OF THE NATIONAL FUEL GAS CODE (NFPA NO. 54) AND IN ACCORDANCE WITH ALL APPLICABLE LOCAL, STATE AND NATIONAL CODES HAVING JURISDICTIONAL AUTHORITY.**

Equipment, which is defective in material or workmanship and within the warranty period, may be returned for credit as follows:

Beckett Burners, Beckett-branded major components and non-Beckett-branded major components that came as original equipment on a Beckett burner or were sold as a replacement part by Beckett should be returned, freight prepaid, to Beckett's home office. Credit will be issued to the customer unless the returned equipment is determined by Beckett to be out of warranty or damaged by user, in which case the equipment will be scrapped.

Note: Beckett is not responsible for any labor cost for removal and replacement of equipment.

THIS WARRANTY IS LIMITED TO THE PRECISE TERMS SET FORTH ABOVE, AND PROVIDES EXCLUSIVE REMEDIES EXPRESSLY IN LIEU OF ALL OTHER REMEDIES, AND IN PARTICULAR THERE SHALL BE EXCLUDED THE IMPLIED WARRANTIES OF MERCHANTABILITY AND FITNESS FOR A PARTICULAR PURPOSE. IN NO EVENT WILL BECKETT BE LIABLE FOR ANY INCIDENTAL OR CONSEQUENTIAL DAMAGE OF ANY NATURE. Beckett neither assumes nor authorizes any person to assume for Beckett any other liability or obligation in connection with the sale of this equipment. Beckett's liability and Customer's exclusive remedy being limited to credit as set forth above.

**R.W. BECKETT CORPORATION**

P.O. Box 1289 Elyria, Ohio 44036

Form No. 61545 R72905

**R.W. BECKETT CORPORATION**

U.S.A.: P.O. Box 1289 • Elyria, Ohio 44036

Canada: R.W. Beckett Canada, Ltd. • Unit #3, 430 Laird Road • Guelph, Ontario N1G 3X7

Form Number 6104BADC R805



\*6104BADC\*



0 45558 00957 0